

**National Report on the Implementation
of the United Nations Programme of Action
to Prevent, Combat and Eradicate
the Illicit Trade in Small Arms and Light Weapons
in All Its Aspects
2009**

Federal Republic of Germany

Missive

The Federal Republic of Germany hereby submits its National Report on the Implementation of the United Nations Programme of Action to Prevent, Combat and Eradicate the Illicit Trade in Small Arms and Light Weapons in All Its Aspects. This document also contains the National Report with regard to the International Instrument to Enable States to Identify and Trace, in a Timely and Reliable Manner, Illicit Small Arms and Light Weapons.

Berlin, February 22, 2010

© 2010 Federal Foreign Office—Division 241

Federal Foreign Office
Division 241
Conventional Arms Control
11013 BERLIN
GERMANY

Telephone +49 30 18 17 42 72
Facsimile +49 30 18 17 5 42 72
Email 241-0@diplo.de

Table of Contents

1	Introductory Remarks	7
2	National Level	8
2.1	National Coordination Agency and National Point of Contact	8
2.1.1	Does your country have a national coordination agency or body that is responsible for policy guidance, research and monitoring of efforts to prevent, combat and eradicate the illicit trade in SALW in all its aspects?	
2.1.2	Does your country have a national point of contact to act as liaison with other States on matters relating to the implementation of the U.N. Program of Action?	
2.2.	Legislation, Regulations and Administrative Procedures	9
2.2.1	What national laws, regulations and administrative procedures exist to exercise effective control over SALW in the areas of production, export, import, transit, retransfer?	
2.2.2	What national measures exist to prevent the manufacture, stockpiling, transfer and possession of unmarked or inadequately marked SALW? How have these been implemented?	
2.2.3	Please describe how national laws, regulations and procedures that impact on the prevention, combating and eradication of the illicit trade in SALW in all its aspects are made public.	
2.3	Law Enforcement and Criminalization	14
2.3.1	What national legislative or other measures exist to make the illegal manufacture, possession, stockpiling and trade of SALW criminal offenses under domestic law? How have these measures been implemented?	
2.3.2	Have those groups and individuals engaged in the illegal manufacture, trade, stockpiling, transfer, possession, as well as financing for acquisition, of illicit SALW been identified, where applicable? What action has been taken under appropriate national law against such groups and individuals?	
2.3.3	What national measures have been taken, including legal or administrative means, against activity that violates a United Nations Security Council arms embargo in accordance with the Charter of the United Nations?	
2.4.	Stockpile Management and Security	16
2.4.1	What national standards and procedures exist for the management and security of SALW stocks held by armed forces, police or other authorized bodies?	
2.4.2	How often are stocks of SALW held by armed forces, police and other authorized bodies reviewed?	
2.4.3	How are those stocks of SALW held by armed forces, police and other authorized bodies that are surplus to requirements identified?	
2.5	Collection and Disposal	18
2.5.1	Please give details of any national programs that have been established and implemented for the responsible disposal of surplus stocks of SALW held by armed forces, police and other authorized bodies.	
2.5.2	Is destruction the means used to dispose of such stocks?	
2.5.3	What national measures exist to safeguard such stocks prior to their disposal?	

- 2.5.4 Subject to the exceptions set out in UNPoA II:16, are all confiscated, seized or collected SALW destroyed?
- 2.5.5 What methods has your country used to destroy surplus stocks of SALW designated for destruction (If appropriate, please make reference to the report of the U.N. Secretary-General [S/2000/1092] of November 15, 2000)?
- 2.5.6 Please give details of any information on SALW confiscated or destroyed within your jurisdiction that is submitted to relevant regional and international organizations.
- 2.6 **Export Controls and Brokering Controls** 22
- 2.6.1 Please describe the system of export and import licensing or authorization, as well as measures on international transit, used by your country for the transfer of all SALW.
- 2.6.2 Please describe the national laws, regulations and administrative procedures used by your country to ensure effective control over the export and transit of SALW. How are these measures implemented?
- 2.6.3 Does your country use authenticated end-user certificates for this purpose?
- 2.6.4 Does your country notify the original exporting State when re-exporting or retransferring previously imported SALW?
- 2.7 **Brokering** 28
- 2.7.1 What national legislation or administrative procedures exist to regulate the activities of those who engage in SALW brokering within national jurisdiction and control (e.g. registration of brokers, licensing or authorization of brokering transactions and appropriate penalties)?
- 2.8 **Marking, Recordkeeping and Tracing** 30
- 2.8.1 Does your country require licensed manufacturers of SALW to apply an appropriate and reliable marking on each weapon as an integral part of the production process? Is this marking unique?
- 2.8.2 Does this marking identify the country of manufacture?
- 2.8.3 How does this marking otherwise allow concerned authorities to identify and trace the relevant weapon?
- 2.8.4 How long are records kept on the manufacture, holding and transfer of SALW under your jurisdiction?
- 2.8.5 What national measures exist for tracing SALW held and issued by the State?
- 2.8.6 Please give details of any steps taken by your country to cooperate in tracing illicit SALW, including the strengthening of mechanisms based on the exchange of relevant information.
- 2.9 **Disarmament, Demobilization and Reintegration (DD&R)** 32
- Please describe (i) any disarmament, demobilization and reintegration (DD&R) programs your country has developed and implemented, including the effective collection, control, storage and destruction of SALW, (ii) how your country has addressed the special needs of children affected by armed conflict, in particular the reunification with their family, their reintegration into civil society, and their appropriate rehabilitation, and (iii) any DD&R programs or activities that your country has supported.

2.10	Awareness-Raising	34
	Please describe (i) any public awareness and confidence-building programs on the problems and consequences of the illicit trade in SALW in all its aspects that your country has developed and implemented (including the public destruction of surplus weapons and the voluntary surrender of SALW) and (ii) any education and public awareness programs on the problems of the illicit trade in SALW in all its aspects that your country has encouraged.	
3	Regional Level	34
3.1	Legally Binding Instruments	34
3.1.1	Has your country been involved in negotiations for the conclusion of legally binding instruments aimed at preventing, combating and eradicating the illicit trade in SALW in all its aspects?	
3.1.2	Where such instruments exist, please describe the steps your country has taken to ratify and fully implement them.	
3.2	Moratoria and Regional Action Programs	35
	Please give details of any support your country has given moratoria or similar initiatives on the transfer and manufacture of SALW, and/or regional action programs to prevent, combat and eradicate the illicit trade in SALW in all its aspects (including cooperation with States concerned in the implementation of these initiatives).	
3.3	Regional Cooperation	35
3.3.1	Please describe any involvement your country has had in the establishment of sub regional or regional mechanisms with a view to preventing, combating and eradicating the illicit trade in SALW across borders (in particular trans-border customs cooperation and networks for information-sharing among law enforcement, border and customs control agencies).	
3.3.2	Please describe any initiatives your country has undertaken to encourage regional and sub regional action on illicit trade in SALW in all its aspects in order to, as appropriate, introduce, adhere, implement or strengthen relevant laws, regulations and administrative procedures.	
4	Global Level	36
4.1	International Instruments Against Terrorism and Organized Crime	36
	What existing international legal instruments against terrorism and transnational organized crime has your country ratified or acceded to?	
4.2	International Cooperation and Assistance	38
4.2.1	Please give details of any assistance, including technical and financial assistance, your country has provided for purposes of supporting the implementation of the measures to prevent, combat and eradicate the illicit trade in SALW in all its aspects as contained in UNPoA.	
4.2.2	Please describe any initiatives your country has undertaken to enhance mutual legal assistance and other forms of cooperation in order to assist investigations and prosecutions in relation to the illicit trade in SALW in all its aspects.	
4.2.3	Please give details of any assistance your country has provided to combat the illicit trade in SALW linked to drug trafficking, transnational organized crime and terrorism.	

- 4.2.4 Please give details of your country's cooperation with Interpol for the purpose of identifying those groups and individuals engaged in the illicit trade in SALW in all its aspects.
- 4.2.5 Please give details of your country's use and support of Interpol's International Weapons and Explosives Tracking System database (including providing relevant information on the illicit trade in SALW).
- 4.2.6 Please give details of your country's cooperation with the U.N. system to ensure the effective implementation of arms embargoes decided by the U.N. Security Council in accordance with the U.N. Charter.
- 4.2.7 Please describe any steps your country has taken in cooperation with other states, or regional or international organizations, to develop common understandings of the basic issues and the scope of the problems related to illicit brokering in SALW.
- 4.2.8 Please give details of any assistance your country could offer to other States concerning stockpile management and surplus disposal or destruction.
- 4.3 **Cooperation with Civil Society and Nongovernmental Organizations** 41
Please give details of cooperation with civil society and nongovernmental organizations in activities related to the prevention, combat and eradication of the illicit trade in SALW in all its aspects, at the national, regional and global levels.
- 4.4 **Information Exchange** 41
- 4.4.1 Please describe any steps taken by your country to exchange information on national marking systems on SALW.
- 4.4.2 Please give details of any information on, inter alia, SALW confiscated or destroyed within national jurisdiction, or other relevant information such as illicit trade routes and techniques of acquisition, that your country has submitted to relevant regional and international organizations.
- 4.5 **Training, Capacity-Building, Research** 41
- 4.5.1 Please describe any initiatives your country has undertaken to enhance cooperation and exchange of experience and training among competent officials, including customs, police, intelligence and arms control officials, at the national, regional and global levels in order to combat the illicit trade in SALW in all its aspects.
- 4.5.2 Please describe any regional and international programs for specialist training on small arms stockpile management and security that your country has developed or supported.
- 4.5.3 Please give details of any action-oriented research aimed at facilitating greater awareness and better understanding of the nature and scope of the problems associated with the illicit trade in SALW in all its aspects that your country has developed or supported.

Annex A	Political Principles Governing the Export of War Weapons and Other Military Equipment, Adopted on January 19, 2000	43
Annex B	Analysis and Evaluation of Information Available to the Federal Criminal Police Bureau on Thefts, Losses and Seizures of SALW in 2008	48
B.1	Introductory Remark	
B.2	Thefts and Losses	
B.3	Seizures	
B.4	Illicit Trafficking	
B.5	Illicit Manufacture	
Annex C	Number of Federal Armed Forces SALW Destroyed in the period 2005-2009	50
Annex D	Location and Sample of Marks	51
Abbreviations		52

1 **Introductory Remarks**

UNPoA

The threat to peace, security and development posed by the destabilising accumulation and spread of small arms and light weapons including their ammunition continues to be a matter of grave concern. Germany is committed to a comprehensive approach to combat, and to contribute to ending, the destabilizing accumulation and spread of small arms and light weapons as well as their ammunition. In the pursuit of this objective, Germany as a Member State of the European Union is guided by the EU Strategy to combat the illicit accumulation and trafficking of SALW and their ammunition, which was adopted by the European Council on 15-16 December 2005.

Germany attaches high importance to fully implementing, while further developing the United Nations Programme of Action to Prevent, Combat and Eradicate the Illicit Trade in Small Arms and Light Weapons in All Its Aspects. Germany has in recent years paid particular attention to the issue of effective and efficient management and security of national stockpiles of conventional arms and ammunition. In 2009 Germany has provided financial assistance to the the development within the United Nations of technical guidelines for the stockpile management of conventional ammunition as a follow-up to UN GA Res 61/72 establishing a Group of Governmental Experts, and UN GA Res 63/61, strongly encouraging States to implement the recommendations of the Group of Governmental Experts.

Germany equally continues to attach utmost importance to the on-going process towards the elaboration of a comprehensive and legally binding Arms Trade Treaty. By adopting resolution 64/48 on 2 December 2009, the United Nations General Assembly decided to convene the United Nations Conference on the Arms Trade Treaty in 2012 to elaborate a legally binding instrument on the highest possible common international standards for the transfers of conventional arms. In 2010, 2011 and 2012, five sessions of a Preparatory Committee will be held to make recommendations to the United Nations Conference on the elements that would be needed to attain an effective and balanced legally binding Arms Trade Treaty and to decide on all relevant procedural matters. Germany expects that the ATT-process will also considerably contribute to efforts with regard to transfer controls of SALW including their ammunition.

2 National Level

2.1 National Coordination Agency and National Point of Contact

- 2.1.1 Does your country have a national coordination agency or body that is responsible for policy guidance, research and monitoring of efforts to prevent, combat and eradicate the illicit trade in SALW in all its aspects?

UNPoA II:4

Germany does not have a single national coordination agency or body. With regard to question 2.1.1,

(i) the Federal Foreign Office is fulfilling the task of coordinating SALW-related foreign policy aspects, including the task as national point of contact; the Federal Foreign Office is chairing regular meetings of representatives from the different ministries with responsibilities for SALW issues, including NGO and industry representatives, to coordinate SALW related policy matters (cf. § 2.1.2 infra);

(ii) the Federal Ministry of the Interior is responsible for the firearms legislation, including the municipal regulation of weapons marking, registration, recordkeeping and sanctioning offenses;

(iii) the Federal Ministry of Defense is responsible for regulating all issues linked to the marking, registration, recordkeeping, and stockpiling of SALW in use with the Federal Armed Forces, and structuring the procurement procedures related to SALW to be used by the Federal Armed Forces;

(iv) the Federal Ministry of Economics and Technology is coordinating export control and brokering issues, and is responsible for legislation concerning war weapons and other military equipment;

(v) the Federal Ministry for Economic Cooperation and Development is addressing SALW issues principally implying development aspects.

- 2.1.2 Does your country have a national point of contact to act as liaison with other States on matters relating to the implementation of the U.N. Programme of Action?

UNPoA II:5

National point of contact to act as liaison with other States on matters relating to the implementation of the U.N. Programme of Action and the International Instrument to Enable States to Identify and Trace, in a Timely and Reliable Manner, Illicit Small Arms and Light Weapons is

Federal Foreign Office
Division 241
Conventional Arms Control
11013 BERLIN
GERMANY
Telephone +49 30 18 17-4272
Facsimile +49 30 18 17 5-4272
Email 241-0@diplo.de

National contact point for the international exchange of information in criminal matters is the Federal Criminal Police Office (Bundeskriminalamt). It is also the national "Expert Contact Point" for the implementation of the UN Firearms Protocol.

Federal Criminal Police Office (Bundeskriminalamt)
Section SO11
65193 WIESBADEN
GERMANY
Telephone +49 611 55 15738
Facsimile +49 611 55 15863
Email SO11@bka.bund.de

2.2. Legislation, Regulations and Administrative Procedures

2.2.1 What national laws, regulations and administrative procedures exist to exercise effective control over SALW in the areas of production, export, import, transit, retransfer?

UNPoA II:2

2.2.1.1 Relevant Statutory Instruments

Provisions concerning SALW to be used solely for military purposes are contained in (i) the Basic Law, i.e. the Constitution of the Federal Republic of Germany, (ii) the Act Implementing Article 26(2) of the Basic Law (War Weapons Control Act), (iii) the Foreign Trade and Payments Act in conjunction with the Foreign Trade and Payments Ordinance.

In addition, on January 19, 2000, the Federal Government adopted Political Principles Governing the Export of War Weapons and Other Military Equipment (hereinafter: "Political Principles") to provide the licensing agencies with guidelines for the scope of and limits to the discretion open to them. The Political Principles are reproduced as Annex A infra. Article 26(2) of the Basic Law provides that "weapons designed for warfare may be manufactured, transported or marketed only with the permission of the Federal Government. Details will be regulated by a Federal Law." This constitutional mandate has been put into federal legislation in the Act Implementing Article 26(2) of the Basic Law (War Weapons Control Act) of April 20, 1961, as amended.¹

2.2.1.2 Statutory Dichotomy "War Weapons"—"Other Military Equipment"

German law on export of weaponry—including SALW—is consistently structured following a terminological dichotomy. While the export of so-called "other military equipment" is subject to general foreign trade law outlined in § 2.2.1.2. infra, i.e. the rules contained in the Foreign Trade and Payments Act and the Foreign Trade and Payments Ordinance, it is the War Weapons Control Act which specifically governs the law on export of war weaponry. The scope of both terms is defined enumeratively by two different lists, pursuant to which -"war weapons" are those defense items contained in the War Weapons Schedule, as annexed to section 1(1) of the War Weapons Control Act, and -"other military equipment" are those defense items contained in Part I section A of the Exports Schedule, i.e. the Annex to section 5(1) of the Foreign Trade and Payments Ordinance.

¹ 1961 Federal Law Gazette I-444.

Applied to the definition of the term “small arms and light weapons” in the footnote to preambular paragraph 3 of the OSCE Document on Small Arms and Light Weapons, the terminological distinction leads to the following conclusion: Whereas light weapons without exception are covered by items enumerated in the War Weapons Schedule and thus always constitute “war weapons,” this is not the case as to revolvers, self-loading pistols, rifles and carbines, even if the weapon in question is made or modified for military use and therefore covered by the small arms definition.

Weapons pursuant to the footnote to preambular paragraph 3 of the OSCE Document on Small Arms and Light Weapons	War Weapons Schedule item no.
I Small Arms	
I : a Revolvers	“Other military equipment,” } on which the War Weapons Control Act does not apply (cf. § 1.2.1.2.2 infra)
I : b Self-loading pistols	
I : c Rifles	
I : d Carbines	
I : e Sub-machine guns	29(b)
I : f Assault rifles	29(c)
I : g Light machine guns	29(a)
I Light Weapons	
I	
I : a Heavy machine guns	29(a)
I : b Hand-held under-barrel grenade launchers	30
I : c Mounted grenade launchers	30

d		
I : c	Portable anti-aircraft guns	31
I : e	Portable anti-tank guns	31
I : f	Recoilless rifles	31
I : g	Portable launchers of anti-tank missile and rocket systems	10 or 37
I : h	Portable launchers of anti-aircraft missile systems	10
I : i	Mortars of calibers less than 100 mm	31

War Weapons

The War Weapons Control Act stipulates that all handling of “war weapons” requires prior approval; this requirement primarily refers to the manufacture, acquisition and transfer of actual control, to all types of transport (within Germany; import, export and transit), and to deals by intermediaries, even if the war weapons do not enter German territory. Any manufacturing, acquisition, transport, and transfer of, as well as trade with war weaponry requires a public license to be issued before engaging in these activities. As a rule, these licenses are granted individually for a specific period of time, hereby covering a limited number of pieces. Licenses are only granted after a reliability test, in the course of which the central penal register is consulted. The Federal Ministry of the Interior and the competent ministries in those federal states, where licensable transactions shall take place, have to give their consent prior to the issuance of a license.

Pursuant to section 6 of the War Weapons Control Act, there is no legal right to receive a license. Instead, such a license must be refused if there is a danger that the war weapons will be used in a way, which disturbs peace, that international commitments entered into by Germany will be violated, or that the applicant is not sufficiently reliable to undertake the envisaged action. Beyond this, the issuance or refusal of an export license is subject to the political discretion of the Federal Government, and it uses its discretion in line with the “Political Principles” of January 19, 2000. The validity of the license depends on the type of

transaction. Thus, a transport license normally will have a shorter validity than a manufacturing license. German law as it stands knows of no licenses, which are unlimited in time.

As lawmaking in the field of war weaponry is a matter of exclusive federal legislation, the federal states (Länder) have the right to legislate in matters concerning SALW not designed as war weapons only to the extent the Federal Republic has refrained from legislating on the federal level; Article 74(1)(4a) of the Basic Law. After the entry into force, on April 1, 2003, of the most recent amendment to the Weapons Act, the federal states will practically only retain the right to legislate on state police SALW issues and on the administration of non-military SALW recordkeeping, where a parallel system applies with a federal back-up register of SALW maintained by the Federal Police and local registers on non-military SALW ownership.

Other Military Equipment

The export of so-called “other military equipment” is subject to the rules contained in the Foreign Trade and Payments Act and the Foreign Trade and Payments Ordinance. The applicant has a right to receive an export license unless a license would entail a violation of section 7 of the Foreign Trade and Payments Act (cf. § 1.2.1.1 supra) by jeopardizing the security of the Federal Republic of Germany, disrupting the peaceful coexistence of nations, or considerably disrupting Germany’s foreign relations. The “Political Principles” of January 19, 2000 apply equally on “other military equipment.”

- 2.2.2 What national measures exist to prevent the manufacture, stockpiling, transfer and possession of unmarked or inadequately marked SALW? How have these been implemented?

UNPoA II:8

2.2.2.1 Manufacture

Provisions establishing obligations to mark war weapons are contained in section 12(7)(3) of the War Weapons Control Act in conjunction with section 13 of the Second Ordinance Implementing the War Weapons Control Act. No exceptions are allowed from the obligation to mark war weapons.

The marking of firearms by industry is governed by section 24 (1) through (5) of the Weapons Act. Arms manufacturers and arms dealers are under an obligation to warrant that every firearm produced, to be used, sold or imported in the area of application of the Weapons Act is duly, and uniquely, marked. Section 14 of the Weapons Act establishes, for firearms developed prior to 1871 or manufactured prior to January 1, 1945, very narrow exceptions from the general marking obligation imposed on manufacturers. If unmarked weapons not falling under section 14 of the Weapons Act are found, the competent authorities, as a rule, submit them to destruction, unless they constitute evidence in a criminal case under investigation or pending a final ruling, or are retained in order to be used for educational purposes of federal or state police forces.

Manufacture of unmarked or inadequately marked SALW constitutes an administrative offense pursuant to section 53(1)(9) of the Weapons Act.

2.2.2.2 Stockpiling

German law does not expressly regulate stockpiling of unmarked or inadequately marked SALW, but considers it to be a case to be subsumed under “possession of unmarked or inadequately marked SALW,” which constitutes an administrative offense; see *infra* § 2.2.2.5. If unmarked weapons not falling under section 14 of the Weapons Act (see *supra* § 1.2.2.2) are found, the competent authorities, as a rule, submit them to destruction, unless they constitute evidence in a criminal case under investigation or pending a final ruling, or are retained in order to be used for educational purposes of federal or state police forces.

2.2.2.3 Transfer and Retransfer

Under section 12(7)(3) of the War Weapons Control Act in conjunction with section 13 of the Second Ordinance Implementing the War Weapons Control Act and under section 24 (1) through (5) of the Weapons Act, all war weapons as well as firearms commercially produced in, or imported or otherwise transferred into, Germany must be marked with the sign of the producer or the importer. The mark must be of a readily recognizable and permanent nature. Transfer of unmarked or inadequately marked SALW constitutes an administrative offense pursuant to section 53(1)(9) of the Weapons Act.

In case of the retransfer of SALW that have previously been imported, the original exporting state is, as a rule, notified before the retransfer of the weapons. A standardized procedure is observed in relation to States participating in the Wassenaar Arrangement; authenticated end-user certificates are used.

2.2.2.4 Possession

Possession of unmarked or inadequately marked SALW constitutes an administrative offense pursuant to section 53(1)(9) of the Weapons Act.

2.2.3 Please describe how national laws, regulations and procedures that impact on the prevention, combating and eradication of the illicit trade in SALW in all its aspects are made public.

UNPoA II:23

Federal, or eventually state, legislation on SALW aspects—irrespective of whether it takes the form of Act, Ordinance or Notification—is, in virtue of a constitutional principle and without any exception, published in the Federal Law Gazette (Bundesgesetzblatt), in the Federal Gazette (Bundesanzeiger) or in the state law gazettes, as the case may be. Newer federal and state legislation is accessible on the Internet under www.gesetze-im-internet.de. Also English language translations of the Basic Law, the War Weapons Control Act, the Foreign Trade and Payments Act and relevant parts of the Weapons Act are easily to be found there. SALW-related instructions addressed to the Federal Armed Forces are, as a rule, collected in the relevant manuals, which are available upon request, unless classified.

2.3 Law Enforcement and Criminalization

- 2.3.1 What national legislative or other measures exist to make the illegal manufacture, possession, stockpiling and trade of SALW criminal offenses under domestic law? How have these measures been implemented?

UNPoA II:3

The criminalization of illegal manufacture, possession, and trade of SALW under German law can be summarized as follows. German law does not expressly regulate illegal stockpiling, but considers it to be a case to be subsumed under “illegal possession of SALW.”

→ Legislative source	Weapons Act	War Weapons Control Act	Foreign Trade and Payments Act
↓ Offense	applicable only on SALW not qualified as war weapons	applicable only on SALW qualified as war weapons	applicable only in cases of transboundary trade pursuant to section 1(1)
Illegal manufacture of SALW	Section 51 (1) and 52(1)(1) in conjunction with section 2(1) or (3) Standard case: Imprisonment (section 51(1): 1-5 years, section 52(1)(1): 6 months–5 years) Section 51(2) and 52(5) Major (serious) case: Imprisonment (1–10 years) Section 51(3) and 52(6) Minor (less serious) case: Imprisonment (not exceeding 3 years) or imposition of fine	Section 22a(1)(1) Standard case: Imprisonment (1–5 years) Section 22a(2) Major (serious) case: Imprisonment (1–10 years) Section 22a(3) Minor (less serious) case: Imprisonment (not exceeding 3 years) or imposition of fine	
Illegal possession of SALW	Section 51(1) and 52(1)(1) in conjunction with section 2(1) or (3) Standard case: Imprisonment (section 51(1): 1-5 years, section 52(1)(1): 6 months–5 years) Section 51(2) and 52(5) Major (serious) case: Imprisonment (1–10 years) Section 51(3) and 52(6) Minor (less serious)	Section 22a(1)(2) Standard case: Imprisonment (1–5 years) Section 22a(2) Major (serious) case: Imprisonment (1–10 years) Section 22a(3) Minor (less serious) case: Imprisonment (not exceeding 3 years)	

	case: Imprisonment (not exceeding 3 years) or imposition of fine		
Illegal trade in SALW	Section 51(1) and 52(1)(1) in conjunction with section 2(1) or (3) Standard case: Imprisonment (section 51(1): 1-5 years, section 52(1)(1): 6 months–5 years) Section 51(2) and 52(5) Major (serious) case: Imprisonment (1–10 years) Section 51(3) and 52(6) Minor (less serious) case: Imprisonment (not exceeding 3 years) or imposition of fine	Section 22a(1)(2) and (4) Standard case: Imprisonment (1–5 years) Section 22a(2) Major (serious) case: Imprisonment (1–10 years) Section 22a(3) Minor (less serious) case: Imprisonment (not exceeding 3 years)	Section 34(2) in conjunction with section 7 Standard case: Imprisonment (not exceeding 5 years) or imposition of fine —if the violation jeopardizes Germany’s security of the Federal Republic of Germany, disrupts the peaceful coexistence of nations, or considerably disrupts Germany’s foreign relations Section 34(6) in conjunction with section 7 Major (serious) case: Imprisonment (of at least 2 years) —if the violation entails the danger of a serious detriment to Germany’s external security See § 1.3.3 for the legal implication if the illegal trade in SALW should violate an arms embargo imposed by the United Nations Security Council

2.3.2 Have those groups and individuals engaged in the illegal manufacture, trade, stockpiling, transfer, possession, as well as financing for acquisition, of illicit SALW been identified, where applicable? What action has been taken under appropriate national law against such groups and individuals?

UNPoA II:6

See the analysis and evaluation of information available to the Federal Criminal Police Bureau on thefts, losses and seizures of SALW in 2009 in Annex B.

- 2.3.3 What national measures have been taken, including legal or administrative means, against activity that violates a United Nations Security Council arms embargo in accordance with the Charter of the United Nations?

UNPoA II:15

The sale, supply, transfer, export of and brokering services related to military equipment, including SALW, to a destination under an arms embargo imposed by the United Nations Security Council in accordance with the Charter of the United Nations are prohibited. Section 69a to 69p Aussenwirtschaftsverordnung (German Foreign Trade Ordinance) implement arms embargoes into national law and regulate these prohibitions. Violations of these restrictions—for instance by exporting SALW to embargoed destinations—are considered a serious crime and thus consistently prosecuted. Sanctions range from 6 months to 5 years of imprisonment.

2.4. Stockpile Management and Security

- 2.4.1 What national standards and procedures exist for the management and security of SALW stocks held by armed forces, police or other authorized bodies?

UNPoA II:17

2.4.1.1 Federal Armed Forces

Within the Federal Armed Forces, the security of SALW stocks is governed by the following regulations:

- (i) “Guidelines Concerning the Infrastructure for Military Stockpile Facilities”
- (ii) Federal Armed Forces Regulation 2/30 “Military Security”
- (iii) Federal Army Regulation 110/100 “Military Security in the Army”

The documents referred to under (ii) and (iii) ascertain the methods for the organization and handling of, as well as procedures for, stocks, daily use and transportation of SALW. Additional regulations targeting local requirements as to achieve the requisite military security framework are also provided.

2.4.1.2 Federal and State Police Forces

The security of SALW stocks held by federal and state police forces is governed by service regulations, effectively foreclosing any access of non-authorized persons. All police weaponry is centrally, and closely, registered in Federal Police and Federal Criminal Police Bureau records.

With regard to Federal Police Forces, a general Administrative Directive has been issued by the Federal Ministry of Interior concerning the German Weapons Act (WaffVwV – BMI). Next to general provisions it contains rules concerning equipment, provisioning and administration as well as handling of weapons and ammunition.

- 2.4.2 How often are stocks of SALW held by armed forces, police and other authorized bodies reviewed?

UNPoA II:18

2.4.2.1 Federal Armed Forces

Within the Federal Armed Forces, a distinctive control system is in use, the periodicity of which may be summarized as follows:

- (i) Guard and MP Units: 100% inventory check at each change of shift

- (ii) Combat units: Routine checks are carried out on a weekly basis
- (iii) Depots and stockpile facilities: Routine checks are carried out every two weeks; additionally, non-periodical checks are carried out after any movement of any kind of SALW.

Periodical as well as challenge inspections carried out by higher command authorities further add to the reliability of the system. Detailed documentation is established on every control measure.

2.4.2.2 Federal and State Police Forces

For SALW and the corresponding ammunition detailed records need to be kept. The head of the office concerned is responsible for a yearly check of all SALW concerning:

- Completeness
- Serviceability
- Security of storage

All SALW and their ammunition need to be checked at least once a year by a weapons technician concerning handling and usability. At every shift rotation at police stations, it is checked whether all service weapons are available. Higher command authorities carry out periodical as well as challenge inspections. Detailed documentation is established on every control measure.

2.4.3 How are those stocks of SALW held by armed forces, police and other authorized bodies that are surplus to requirements identified?

UNPoA II:18

2.4.3.1 Federal Armed Forces

German security and defense policy is governed by values and principles as embedded, inter alia, in the Charter of the United Nations, in basic EU and OSCE documents, and in the Basic Law. Germany's national interest in the preservation of freedom, security and the welfare of its citizens, as well as in the integrity of its territory, is closely connected with her interest in a peaceful and lasting order in Europe and for the nations of the world. For Germany, NATO remains the foundation for common defense and the primary political framework for the participation of German forces in crisis operations and peace missions. Since 2006 the Federal Armed Forces also make substantial contributions to EU security operations. Moreover, Germany will continue to contribute to United Nations and OSCE peace missions. Based on these political principles, the planning process regarding the structure and strength of armed forces as well as the respective operational requirements of these forces will determine the level of surplus stocks.

2.4.3.2 Federal and State Police Forces

Not unlike the build-up of military surplus stocks, surplus of police weaponry is mainly resulting from decisions to modernize and replace weaponry in active use or to redefine the service- or shelf-life of existing weapons. Special surplus markings on police weapons indicate that they have been removed from active service and integrated in a disposal process (cf. § 2.5.2.2 infra) which is documented in the federal back-up register of SALW maintained by the Federal Police.

2.4.3.3 Federal Customs Administration

Surplus SALW used by customs officers are basically treated as police weaponry. Their destruction is documented in the central weapons register of the Federal Revenue Administration. SALW seized in the course of customs controls are, upon release by the investigating authority, transferred to the central armory at the Procurement Office of the Federal Customs Administration where appropriate records are kept.

2.5 Collection and Disposal

2.5.1 Please give details of any national programs that have been established and implemented for the responsible disposal of surplus stocks of SALW held by armed forces, police and other authorized bodies.

UNPoA II:18

2.5.1.1 Federal Armed Forces

Introductory Remark

Interoperability within NATO permits the sale of surplus SALW to NATO countries. However, such sales are only approved on a case by case basis and are subject to the relevant legal provisions on SALW exports.

Techniques for Destruction

For the reduction, demilitarization and utilization of SALW, the Federal Armed Forces mainly apply the severing (cutting) procedure, partly in combination with plastic deformation.

Details on Recordkeeping, Authority for Destruction, and Destruction Sites

The reduction or destruction of SALW earmarked for disposal or removed from active service is conducted in four regional maintenance facilities of the Federal Armed Forces in cooperation with the German industry. SALW earmarked for reduction are transported in a convoy protected by escort vehicles. The armed escort squad carries the records on number, type and condition of the weapons with it. A security check is performed for each weapon at the Federal Armed Forces maintenance facilities.

In the case of removal from active service, serviceable parts or components are removed and stored as spare parts. In the case of reduction, the weapon is disassembled or the parts of it are separated according to a material separation scheme, whereupon the weapon or its parts are entirely destroyed in accordance with the planned reduction procedure, thus without keeping any spare parts. The destruction is performed either at the Federal Armed Forces Maintenance Facility or at a German industrial facility. The disposal is documented in a protocol. After reduction or removal from active service, each weapon is written off the Federal Armed Forces' inventory records. The documentation is kept at the Federal Armed Forces Materiel Office.

Seized or Confiscated Weapons

SALW seized or confiscated by Federal Armed Forces outside of Germany during operations under NATO or EU control are destroyed, either through NATO or EU forces or through local authorities.

Surplus Weapons 1990—2009

Germany is reorganizing its armed forces and constantly adapting its holdings of armaments and equipment to the new requirements. In 2009, the Federal Armed Forces destroyed 76.559 SALW. Consistent with national German policy the holdings of the former standard issue rifle were not sold but destroyed. Within the period 1990 to 2009, the Federal Armed Forces have destroyed a total of 2.303.252 SALW. Additional data about SALW destroyed by the Federal Armed Forces are provided in Annex C.

2.5.1.2 Federal Police

Weapons seized or confiscated by the Federal Police are usually destroyed, hereby using the following techniques: meltdown in blast furnaces, shredding, torch cutting. In the case of rare weapons, collection for the purpose of education and training of Federal Police forces may alternatively apply.

2.5.1.3 Federal Customs Administration

In 2009, the Federal Customs Administration destroyed 5188 short-rifle weapons and 3 sub-machine guns, either in its own central repair facility for weapons (“four-eyes-principle”), or by certified contractors under supervision of a Customs Officer. The technical destruction is mainly done by severing (cutting), partly in combination with plastic deformation, using mechanical or thermal separation procedures. Documentation on the destruction process contains each weapon’s type and serial number.

2.5.2 Is destruction the means used to dispose of such stocks?

UNPoA II:18

2.5.2.1 Federal Armed Forces

Surplus SALW will be destroyed or, in a limited number of cases and on restrictive grounds, be sold. Within the Federal Armed Forces stocks declared as surplus will be transferred from the military organization to the Federal Agency for Defense Procurement and Technologies. The main destruction method is cutting, in addition a combination of cutting and plastic deformation is also used.

2.5.2.2 Federal and State Police Forces

Destruction is the main means used by federal and state police forces to dispose of surplus stocks. However, in the case of rare weapons, these are collected for the purpose of education and training of federal and state police forces. As to pistols of caliber 9 mm*19 mm, sale to authorized dealers is permissible.

2.5.2.3 Federal Customs Administration

The Federal Customs Administration disposes of surplus stocks by employing destruction, transfer to authorized authorities and institutions; and only in the case of non-military SALW—sale to authorized dealers.

2.5.3 What national measures exist to safeguard such stocks prior to their disposal?

UNPoA II:18

2.5.3.1 Federal Armed Forces

Within the Federal Armed Forces, additional measures are not required. Surplus stocks are stored, monitored and treated on the same high standard as military SALW in active use; see § 2.4.1.1 and § 2.4.2.1 supra.

2.5.3.2 Federal and State Police Forces

Surplus stocks are safeguarded in the manner as police SALW in active use; see § 2.4.1.2 and § 2.4.2.2 supra.

2.5.3.3 Federal Customs Administration

Surplus SALW is stored in secure lockers or in secure accommodations at office level, or in the central armory at the Procurement Office of the Federal Customs Administration.

2.5.4 Subject to the exceptions set out in UNPoA II:16, are all confiscated, seized or collected SALW destroyed?

UNPoA II:16

2.5.4.1 Federal Armed Forces

SALW seized or confiscated by Federal Armed Forces outside of Germany during operations under NATO or EU control were, and are, destroyed, either through NATO, EU or U.N. forces or through local authorities.

2.5.4.2 Federal and State Police Forces

With the exception of rare weapons, which are collected for the purpose of education and training of federal and state police forces, confiscated, seized or collected SALW are, as a rule, destroyed.

2.5.4.3 Federal Customs Administration

SALW confiscated, seized or collected by customs authorities are transferred, as the case may be, to study collections maintained by the Federal Armed Forces, the Federal Criminal Police Bureau, the Federal Police, the official proof-testing agencies, the Customs Criminological Office, the German Customs Museum, the Training Center of the Federal Revenue Administration, Customs Staff Training Centers; or —only in the case of non-military SALW— sold to authorized dealers.

2.5.5 What methods has your country used to destroy surplus stocks of SALW designated for destruction (If appropriate, please make reference to the report of the U.N. Secretary-General [S/2000/1092] of November 15, 2000)?

UNPoA II:19

2.5.5.1 Federal Armed Forces

Cf. § 2.5.1.1 supra.

2.5.5.2 Federal and State Police Forces

Cf. § 2.5.1.2 supra.

2.5.5.3 Federal Customs Administration

Cf. § 2.5.1.3 supra.

2.5.6 Please give details of any information on SALW confiscated or destroyed within your jurisdiction that is submitted to relevant regional and international organizations.

UNPoA II:23

2.5.6.1 Introductory Remarks

Detailed information on SALW confiscated or destroyed both within the German jurisdiction and, with the assistance of the Federal Armed Forces in the context of peace-keeping missions, overseas is regularly submitted to the Organization for Security and Cooperation in Europe (OSCE) in Annex 2 (Template for the Annual Information on SALW Identified as Surplus and/or Seized and Destroyed) to the “Information Exchange Pursuant to the OSCE Document on Small Arms and Light Weapons”. Another relevant source as to data on SALW confiscated or destroyed within Germany is the annual Schengen progress report.

2.5.6.2 Federal Armed Forces

SALW seized or confiscated by Federal Armed Forces outside of Germany during operations under NATO or EU control are destroyed, either through NATO or EU forces or through local authorities.

2.5.6.3 Federal and State Police Forces

For the purpose of this National Report on Implementation, the Federal Criminal Police Bureau has compiled data on SALW seized in Germany in 2009. Annex B infra reproduces the Bureau’s “Analysis and Evaluation of Information Available to the Federal Criminal Police Bureau on Thefts, Losses and Seizures of SALW in 2009.”

2.5.6.4 Federal Customs Administration

The Customs Criminological Office reports the number of SALW seized each year by the Customs investigation Service to the Federal Ministry of Finance; these data are included in the annual statistics of the Federal Criminal Police Bureau and in Schengen progress reports. However, the number of SALW destroyed is not collected. Nor does the Customs Criminological Office report to international organizations.

The Procurement Office of the Federal Customs Administration, when ordering destruction or other disposal of SALW, provides information on purchasers or authorities at which the SALW will in future be held. The Federal Ministry of Finance is supplied with information on the disposal or destruction of service SALW. Data on confiscated and destroyed weapons are part of the annual reporting within OSCE and UN

2.6 Export Controls and Brokering Controls

2.6.1 Please describe the system of export and import licensing or authorization, as well as measures on international transit, used by your country for the transfer of all SALW.

UNPoA II:11

2.6.1.1 Introduction into German Export Control Policy

Germany's policy on exports of military equipment is part of its foreign and security policy, which is aimed at preserving peace and stability and ensuring the respect of human rights. It corresponds to decisions on values which have been firmly entrenched across the political spectrum since the Basic Law was promulgated. There is a broad consensus in the Lower House of the Federal Diet (Deutscher Bundestag) on the legal and political foundations of Germany's policy on exports of military equipment and the restrictive approach taken by the government.

In particular, export bans adopted by the United Nations Organization or other international organizations prohibit delivery of military equipment to embargoed destinations. The range of embargoed goods is basically identical with the military equipment as set forth in Part I section A of the Exports Schedule, i.e. the Annex to section 5(1) of the Foreign Trade and Payments Ordinance. Section 69a to 69p Aussenwirtschaftsverordnung (German Foreign Trade Ordinance) implement arms embargoes into national law and regulate these prohibitions.

Decisions on the export of war weapons and other military equipment are based on the Political Principles, adopted on January 19, 2000, (see Annex A infra) and on the relevant European and international commitments entered into by the Federal Government, particularly on the European Council Common Position defining common rules governing control of exports of military technology and equipment adopted on December 8, 2008. Exports of war weapons and other military equipment both to NATO and to EU Member States as well as to "NATO equivalent countries," such as Australia, Japan, New Zealand or Switzerland, are considered to be in line with Germany's security interests and are, in principle, unrestricted. Exports of war weapons to third countries, in contrast, are only feasible if indicated by paramount foreign and security policy interests, bearing in mind the interests of NATO. In this context, employment aspects are not allowed to play a significant role.

The export of other military equipment is authorized to the extent that the provisions of section 7 of the Foreign Trade and Payments Act do not prescribe otherwise; these provisions aim to protect the security of the Federal Republic of Germany, the peaceful coexistence of nations, and foreign relations. Decisions on exports of war weapons and other military equipment are made on the basis of a thorough examination of each individual case. The issue of respect for human rights in the countries of destination is a key factor in deciding whether or not to grant licenses, which is particularly true in the case of processing applications for the export of SALW. Another significant aspect is whether an armed conflict is, in fact, ongoing, or is likely between the country of destination and its neighboring states. In general, it must be certain that the military equipment will only be used for the purposes of defense and remain in the country of destination.

As legally binding instrument, the European Council Common Position defining common rules governing control of exports of military technology and equipment adopted on December 8, 2008 also comprise the common export criteria set forth in section III paragraph (A) of the OSCE Document on Small Arms and Light Weapons. The restrictive attitude of Germany's export policy is reflected in the fact that military equipment represents only a minor proportion of the entirety of German exports. For example, exports of war weapons traditionally account for less than 0.5 % of all exports, and are mainly directed to countries which are members of NATO or of the OECD. This is particularly valid for SALW.

2.6.1.2 Types of Licenses for Final Exports

German law on foreign trade and payments defines four types of licenses for final exports individual licenses (see § 2.6.1.2.1 infra), maximum amount licenses, collective export licenses (see § 2.6.1.2.2 infra); and general licenses (see § 2.6.1.2.3 infra). As the second is only a variant of the first, they are dealt with here jointly.

Individual Licenses and Maximum Amount Licenses

The basic export license is the "individual license" (Einzelgenehmigung). It authorizes the export of one or several pieces of equipment to one recipient upon application. As a special type of individual license, a "maximum amount license" (Hoechstbetragsgenehmigung) can be issued. This license permits the export of equipment for several contracts, e.g. in the context of a framework contract with a customer, up to the maximum amount authorized (i.e., the likely sales in one year).

Collective Export Licenses

Rather than applying for individual licenses, it is possible to issue a "collective license" (Sammelausfuhrgenehmigung) to certain exporters. This license permits the export of a group of equipment to several recipients.

General Licenses

General Licenses are inapplicable for SALW.

2.6.1.3 Licenses for Temporary Exports

Licenses for temporary exports are issued in principle according to the same provisions and administrative proceedings as licenses for final exports. Thus, licenses for the presentation of sensitive goods on a trade fair hosted in a country considered as a critical destination may be refused. The applications for temporary exports are assessed according to the same criteria as those for final exports. The duration of a license may be distinct from usual license durations. The only relief for the applicant is that he is not obliged to file end-user documents with the application. However, the license may provide that the exported good must be re-imported to Germany. This means that the exporter must prove that the goods have been re-imported to Germany upon expiration of the license. Usually, the exporter provides the Federal Office of Economics and Export Control (BAFA) with suitable documents issued by a German customs or tax authority, or with similar evidence. Hunting arms may be temporarily exported without a license in accordance with section 19(1)(16) of the Foreign Trade and

Payments Ordinance. However, the hunting arms must be reimported to Germany within three months. Moreover, this statutory rule provides for exemptions for certain means of transport. Similar to temporary exports, reexports are, in general, treated according to general rules.

2.6.1.4 Period of Validity of Licenses

In general, German export licenses are valid for a time period of two years. They may only once be extended for another two years. However, individual licenses for the export of military equipment are valid only for one year; they may be extended for one additional year. The reason for this exception is that licenses for the export of military equipment are in particular subject to a political evaluation of the given circumstances which may vary in time. Thus, there is a maximum duration of validity of export licenses in case of military equipment of two years and in case of dual-use goods of four years (including possible extensions). The proceedings for an application for extension are governed by the same strict principles as those that apply when issuing a new license. In case of temporary exports, the duration of a license may be stipulated according to the circumstances prevailing in the individual case (e.g. for the duration of a trade fair). In contrast to all other types of licenses, general licenses are issued *ex officio*. They expire at the end of a calendar year and may be extended for further calendar years.

2.6.1.5 Licensing Authority and Legal Recourse

War Weapons

The Federal Government is the licensing authority under the War Weapons Control Act; section 11(1) of the said Act. It is authorized to assign as follows, by ordinance not requiring the consent of the Upper House of the Federal Diet (Bundesrat), the power to grant and cancel licenses

- (i) for the ambit of the Federal Armed Forces: to the Federal Ministry of Defense;
- (ii) for the ambit of the Federal Customs Administration: to the Federal Ministry of Finance;
- (iii) for the ambit of the authorities or agencies responsible for maintaining law and order as well as prison authorities: the Federal Ministry of the Interior;
- (iv) for all other areas: the Federal Ministry of Economics and Technology.

Applications from companies should therefore normally be submitted to the Federal Ministry of Economics and Technology; the ministry decides on these projects in close cooperation with the Federal Foreign Office and the Federal Ministry of Defense. While the Federal Ministry of Economics and Technology is licensing authority in routine cases not falling in the ambit of other federal ministries, it is the Federal Government, constituted as Federal Security Council, which deliberates politically contingent applications. Following a general principle in German administrative law, applicants whose applications under the War Weapons Control Act are—in whole or in part—dismissed, have recourse to legal review before the administrative courts.

Other Military Equipment

The Federal Office of Economics and Export Control (BAFA) is the licensing authority under the Foreign Trade and Payments Act as far as “other military equipment” is concerned;

section 28(3)(1) of the said Act. Sensitive or significant projects are, however, regularly submitted to the Federal Ministry of Economics and Technology and the Federal Foreign Office for political assessment. Applications for the export of other military equipment should be submitted to Federal Office of Economics and Export Control (BAFA), which also decides on the applications. Applicants, whose applications under the Foreign Trade and Payments Act are— in whole or in part— dismissed, have ultimately recourse to legal review before the administrative courts.

2.6.1.6 Circumstances in Which a License is Not Required

Exemptions from the obligation to obtain a license are provided for in section 19 of the Foreign Trade and Payments Ordinance. Thus, in the cases of exports mentioned in this provision, no license is required. Depending on the value of the transaction concerned, further exemptions may apply. The list of exemptions set forth in section 19 of the Foreign Trade and Payments Ordinance comprises mainly day-to-day business matters having no major importance for export control issues.

Other exemptions from the obligation to obtain a license are provided for in section 5 of the Foreign Trade and Payments Ordinance in conjunction with part 1 chapter a Nr.0001 Exports Schedule. These apply to hunting weapons with a smoothbore barrel that are not specially constructed for military purposes and/or are not able to fire in an automatic mode or in a semi-automatic mode more than 3 rounds without reloading. Such weapons do generally not require an export licence. The same applies to the export of rimfire weapons (not full-automatic) and rimfire ammunition with a caliber .22 and not specially constructed for military purposes.

2.6.1.7 Revocation of Licenses

A license may be revoked if the applicant does not comply with the terms and conditions set forth in the license. If new facts occur after a license has been granted, which would have justified the denial of the license, the license may be revoked in case of a danger for public interests. The license may also be revoked in order to prevent major damage to public interests. In certain cases the applicant may be entitled to damages, if he made use of his license in good faith before revocation.

Under specific conditions it is even possible to prohibit legal transactions and activities in individual cases. Especially exports and transfers, which could significantly disturb the peaceful coexistence between nations or seriously disrupt the Federal Republic of Germany's security or external relations (Section 2 paragraph 2, Foreign Trade and Payments Act) could be affected by this rule. Section 2 paragraph 2 enables the government to take effective measures very fast in order to prevent concrete imminent danger”.

2.6.1.8 Embargoed Destinations and Areas of Concern

See § 2.6.1.1 supra.

2.6.1.9 Advance Rulings

Applying for advance rulings has turned out to be a valuable instrument in practice, as this instrument permits enterprises to foresee and to know from an early date whether they would stand a chance of obtaining the final export license needed to help the proposed deal materialize—provided, of course, that the circumstances prevailing at the date on which the

inquiry was submitted have not changed. In advance rulings, the same procedural rules and material criteria apply as in ordinary license cases. Advance rulings concerning war weaponry are made by the Federal Foreign Office after consultation with other Federal Ministries and Agencies, whereas cases dealing with other military equipment lay with the ruling authority of the Federal Office of Economics and Export Control (BAFA). Sensitive and significant projects in the field of other military equipment are, by way of recourse, submitted to the Federal Government. An advance ruling is legally binding upon the Federal Office of Economics and Export Control (BAFA).

- 2.6.2 Please describe the national laws, regulations and administrative procedures used by your country to ensure effective control over the export and transit of SALW. How are these measures implemented?

UNPoA II:12

As explained in § 1.2.1.1 supra, German exports of military equipment including SALW and their ammunition are regulated in

- (i) the Basic Law, i.e. the Constitution of the Federal Republic of Germany,
- (ii) the Act Implementing Article 26(2) of the Basic Law (War Weapons Control Act), and
- (iii) the Foreign Trade and Payments Act in conjunction with the Foreign Trade and Payments Ordinance.

In addition, on January 19, 2000, the Federal Government adopted “Political Principles Governing the Export of War Weapons and Other Military Equipment” to provide the licensing agencies with guidelines for the scope of and limits to the discretion, under which they are to act; see Annex A infra.

The Annex to section 1(1) of the War Weapons Control Act, entitled “War Weapons Schedule,” contains all items, which are considered to be war weapons in the understanding of the War Weapons Control Act. Part I section A of Annex AL to section 5(1) of the Foreign Trade and Payments Ordinance, entitled “Exports Schedule,” contains all items, which are considered to be “other military equipment” in the understanding of the Foreign Trade and Payments Act and of the Foreign Trade and Payments Ordinance. Defense items defined as SALW pursuant to the footnote to the third preamble paragraph of the OSCE Document on Small Arms and Light Weapons can be identified in these lists along the lines discussed in § 2.2.1.2 supra. SALW are mostly covered by the War Weapons Schedule categories, but various categories of Part I section A of the Exports Schedule may apply. The legal treatment of a given SALW depends on whether it constitutes “war weapon” or “other military equipment.” Pursuant to section 6 of the War Weapons Control Act, there is no legal claim to a license. Instead, such license must be refused where war weapons threaten to be used for peace-disturbing acts, where Germany’s obligations under international public law will be violated, or where applicants are unable to prove that they are sufficiently reliable for handling war weapons. Beyond this, the issuance or refusal of an export license is subject to the political discretion of the Federal Government, and it makes use of it in line with the Political Principles reproduced in Annex A.

The export of “other military equipment,” i.e. of defense items not enumerated in the War Weapons Schedule annexed to section 1(1) of the War Weapons Control Act, is subject to general export law contained in the Foreign Trade and Payments Act and the Foreign Trade and Payments Ordinance. The applicant has a right to receive an export license unless a li-

cense cannot be issued because one of the principles set forth in section 7 of the Foreign Trade and Payments Act—safeguarding the security of the Federal Republic of Germany; disruption to the peaceful coexistence of nations; considerable disruption to Germany’s foreign relations—would be violated. Export licenses can only be revoked under certain narrow legal preconditions; these cases occur very rarely in practice. In certain cases, the export of other military equipment does not require an individual license. These exemptions are listed in section 19 of the Foreign Trade and Payments Ordinance and are discussed in more detail in § 2.6.1.6 *infra*. Germany’s national lists are in coincidence with relevant international control lists, such as the Wassenaar Arrangement list and the EU Common List of Military Equipment, as adopted by the EU Council on June 13, 2000.

As to civilian SALW, Germany has implemented Council Directive 91/477/EEC of June 18, 1991, on control of the acquisition and possession of weapons² in her municipal legislation, i.e. in the Weapons Act and the Ordinances Implementing the Weapons Act. Pursuant to Article 12(1) of the Directive, “[t]he possession of a firearm [as defined in Annex I section II to the Directive] during a journey through two or more [EC] Member States shall not be permitted unless the person concerned has obtained the authorization of each of those Member States. Member States may grant such authorization for one or more journeys for a maximum period of one year, subject to renewal. Such authorizations shall be entered on the European firearms pass, which the traveler must produce whenever so required by the authorities of the Member States” (square brackets inserted).

2.6.3 Does your country use authenticated end-user certificates for this purpose?

UNPoA II:12

In order to export war weapons or other military equipment, an end-user document must normally be submitted along with the application. In the case of end-user documents, a distinction is chiefly made between official end-user declarations (exhibitor, government or authority of the country of destination), private end-user assurances (exhibitor, company or private individual), and International Import Certificates (IICs).

The system of end-use control is based on the above mentioned IICs and end-user documents as well as on Delivery Verification Certificates (DVCs) and import documentation provided by customs or tax authorities of third States. End-user documents do also provide for restrictions on reexport to other than the privileged States mentioned in section 3 of Annex II to Council Regulation (EC) No.428/2009 of May 5, 2009, 1334/2000 of June 22, 2000, setting up a Community regime for the control of exports of dual-use items and technology³ (i.e. Australia, Canada, Japan, New Zealand, Norway, Switzerland, and the United States of America), and in case of war weapons to any State.

2.6.4 Does your country notify the original exporting State when re-exporting or retransferring previously imported SALW

UNPoA II:13

Yes, if consented to in an official end-user declaration by the Federal Government. Should such consent not explicitly have been given, no notification will take place.

² □ Official Journal of the European Communities L 256/51 of September 13, 1991.

³ □ Official Journal of the European Communities L 159/1 of June 30, 2000.

2.7 Brokering

- 2.7.1 What national legislation or administrative procedures exist to regulate the activities of those who engage in SALW brokering within national jurisdiction and control (e.g. registration of brokers, licensing or authorization of brokering transactions and appropriate penalties)?

UNPoA II:14

2.7.1.1 Licenses, Registration and Reporting

Physical transactions concerning war weapons located in Germany, including all physical transactions which are preceded by relevant brokering activities, are subject to, and covered by, licensing according to the War Weapons Control Act. All physical transactions of war weapons located in Germany are covered by this licensing system. Thus, all brokering activities relating to war weapons located in Germany which result in a physical transaction are covered by this licensing system. However, as this licensing system did not cover—neither directly nor indirectly—brokering activities relating to war weapons located outside Germany, two new provisions—section 4a and section 40—were inserted in the War Weapons Control Act and in the Foreign Trade and Payments Regulation respectively, covering all SALW. According to these provisions, the following activities are subject to licensing:

- mediating a contract on the acquisition or transfer of war weapons and other military equipment located outside German territory or showing that an opportunity exists for concluding such a contract; or
- concluding a contract on the transfer of war weapons and other military equipment located outside German territory.

Each individual case of arms brokering relating to war weapons and other military equipment located outside of Germany requires a license. Licenses are granted or denied, as the case may be, on the same conditions as export licenses. The brokering activities mentioned above are, however, not subject to licensing under section 4a of the War Weapons Control Act, if the war weapons are to be imported into or transited through German territory in the execution of the contract.

The German law on arms brokering is based on a territorial link, i.e. it is not applicable in cases without any linkage to German territory (unless the broker is a German national located in Germany). Thus, at least one element in the chain of brokering activities has to have ties with the German territory. This means that brokering activities normally fall under German jurisdiction if one or more of the following activities take place in Germany: meeting for negotiations between the interested contract parties with the participation of the broker in question or making use of German telecommunication resources, e.g. by making telephone calls or mailing facsimiles or letters from Germany or by sending emails which are forwarded over a server located in Germany. When German citizens located in Germany engage into brokering abroad without linkage to the German territory this constitutes, however, a license requirement.

As the Federal Government—and upon assignment the Federal Ministry of Economics and Technology—is the licensing authority under the War Weapons Control Act, reference is made to § 2.6.1.5.1 which applies *mutatis mutandis* on brokering licenses. The licensing authority for brokering activities under the Foreign Trade and Payment Regulation is the Federal Office of Economics and Export Control (BAFA). A license for brokering may be re-

voked at any time. The licensing authority shall revoke a license, if, after granting the license, a reason for refusal has become evident, unless the reason is eliminated within a period of time to be determined.

There is no specific requirement for international brokers in Germany to be registered. However, since international brokers need to file an application for each of their brokering activities according to the rules explained above, authorities have good knowledge of who is currently active as an international broker. There is no reporting requirement for international brokers in Germany.

2.7.1.2 Criminalization of Illegal International Brokering Activities

The criminalization of illegal brokering in SALW under German law can handily be summarized as follows:

→ Legis- lative source	Weapons Act	War Weapons Control Act	Foreign Trade and Payments Act
↓ Of- fense	applicable only on SALW not qualified as war weapons	applicable only on SALW qualified as war weapons	applicable only in cases of transboundary trade pursuant to section 1(1)
Illegal brokering in SALW	Section 52(1)(2)(c) in conjunction with sections 2(2) and 21(1), first phrase Standard case: Imprisonment (6 months–5 years) No major (serious) case regulation Section 52(6) Minor (less serious) case: Imprisonment (not exceeding 3 years) or imposition of fine	Section 22a(1)(7) Standard case: Imprisonment (1–5 years) Section 22a(2) Major (serious) case: Imprisonment (1–10 years) Section 22a(3) Minor (less serious) case: Imprisonment (not exceeding 3 years) or imposition of fine	

2.7.1.3 Exporter Not Required to Disclose Brokers Involved in Transaction

In Germany, exporters of military equipment are not legally obliged in the context of the licensing procedure to disclose whether a broker has been involved in a transaction.

2.7.1.4 Number of Revocations or Disbarment of International Brokers

Since there is no formal requirement for international brokers to be registered, there is no revocation or disbarment of international brokers in Germany either. However, in case of an international broker violating German brokering law, it is conceivable that no further individual licenses will be granted to this broker.

2.8 Marking, Recordkeeping and Tracing

- 2.8.1 Does your country require licensed manufacturers of SALW to apply an appropriate and reliable marking on each weapon as an integral part of the production process? Is this marking unique?

UNPoA II:7

2.8.1.1 Introductory Remarks

All war weapons as well as firearms commercially produced in, or imported or otherwise transferred into, Germany must be marked with a unique sign of the producer or the importer. The mark must be of a readily recognizable and permanent nature.

2.8.1.2 Federal Armed Forces

Each weapon of the Federal Armed Forces is unambiguously marked and bears the following information: manufacturer, weapon type, caliber, month and year of delivery ex works, serial number, proof firing stamp, possibly additional marks, such as, e.g., maintenance information. The marks are applied in accordance with the standards of applicable technical manuals and are unique. In order to increase the transparency within the field of marking of SALW Germany has begun the process to introduce the stamp “DE” as a central identification code.

2.8.1.3 Federal and State Police Forces

Pursuant to section 24(1) of the Weapons Act, arms manufacturers and arms dealers are under an obligation to warrant that every firearm be marked with a sign containing data on -their name, a registered corporate name or a registered trademark of the arms manufacturer or arms dealer established in the area of application of the Weapons Act, -the type of ammunition or—if no ammunition is used—the type of projectiles, and -a serial number.

Pursuant to section 6 (1) and (2) of the Proof Firing Act, as amended, a proof firing stamp as well as a property sign – e.g. “BMI” indicating that the weapon is in use with the Federal Ministry of the Interior- are stamped or engraved on all arms used by federal authorities. The Federal Customs Administration, the Federal Police and the state police forces must carry the title holding authorities’ sign. Arms of the state police forces are marked with a state-specific sign of ownership containing an abbreviation of the respective state and/or of the name of the institution. E.g.: The abbreviations “HB” and “Pol.Br.” designate weapons in use with the police force of the Freie Hansestadt Bremen, the smallest German federal state. For an example of a German proof firing stamp, see Annex D infra.

2.8.1.4 Federal Revenue Administration

In addition to the required data as described in § 2.8.1.2 supra, weapons in use with the Federal Revenue Administration are permanently marked with the acronym “BZV.”

- 2.8.2 Does this marking identify the country of manufacture?

UNPoA II:7

Yes, as part of the manufacturer’s mark or the proof firing mark (with the stylized eagle displayed in Annex D denoting “Germany”).

- 2.8.3 How does this marking otherwise allow concerned authorities to identify and trace the relevant weapon?

UNPoA II:7

Not applicable; cf. § 2.8.1 and § 2.8.2 infra.

- 2.8.4 How long are records kept on the manufacture, holding and transfer of SALW under your jurisdiction?

UNPoA II:9

All license holders are obliged to keep the necessary documents for at least ten years in order to make on-site inspections of the supervising authorities possible. Such on-site inspections take place regularly and may be carried out as challenge inspections. Recordkeeping in the federal back-up register of SALW maintained by the Federal Police is unlimited in time, thus warranting that police weaponry can be traced even after the life-time of the weapons. Additionally, each arms manufacturer is obliged to keep an arms manufacturing register (Waffenherstellungsbuch) and a register of the trade in arms (Waffenhandelsbuch). These registers contain information on the production of arms, the recipients of the arms, the production numbers, and the production signs (e.g. registered trademarks or the name of the manufacturer). Upon consultation of the registers, it is possible to determine whether a specific marked arm was manufactured by the company in question. Markings may differ according to clients' wishes, but it is guaranteed that a later identification is possible. As to non-military weapons, inspections take place once a year; they are carried out for by the competent regional administrative authority. Furthermore, Germany has also intensified its efforts in the field of recordkeeping, for example the compulsory period of recordkeeping will be more definite and legally binding in the long term. Concerning war weapons, companies have to observe special reporting obligations by submitting bi-annual statements to the Federal Office of Economics and Export Control (BAFA) on all registered transactions. Every second year the Office carries out inspections based on these statements.

- 2.8.5 What national measures exist for tracing SALW held and issued by the State?

UNPoA II:10

SALW held and issued by State authorities can be traced by referring the marking to registers kept by the Federal Armed Forces, the federal back-up register of SALW maintained by the Federal Police, the central weapons register of the Federal Revenue Administration, as the case may be. In the civil domain small arms can be traced in the same way. The German legislation provides a sophisticated system of marking and registration of small arms which allows the tracing of any lawfully marked weapon.

Pursuant to Articles 123 and 124 of the German Regulations concerning correspondence with foreign countries in legal matters, all police services from foreign countries can request the Federal Criminal Police Office to establish the sales history of a firearm via official channels such as Interpol or Europol.

- 2.8.6 Please give details of any steps taken by your country to cooperate in tracing illicit SALW, including the strengthening of mechanisms based on the exchange of relevant information.

UNPoA III:11

2.8.6.1 Federal Armed Forces

The Federal Armed Forces have established an effective system of cooperation with the Federal Criminal Police Bureau — and, if necessary, via the Bureau with Interpol — concerning theft of SALW occurring in the Federal Armed Forces. During Peace Support Operations (PSO) the Federal Armed Forces are closely in cooperation with local authorities and/or international (i.e. UN) police forces in tracing illicit SALW.

2.8.6.2 Federal and State Police Forces

The process of tracing illicit SALW is, as a rule, initiated by a so-called tracing request forwarded by Interpol to the country of manufacture. In Germany, all measures to trace illegal SALW are undertaken by the Federal Criminal Police Bureau. If a tracing request is received by the Bureau due to indications that the weapon in question appears to be manufactured in Germany without carrying a federal or state authority marking, investigations do not only address the manufacturer (see § 2.8.4 supra), but even the Federal Ministry of Economics and Technology as licensing authority and the Federal Office of Economics and Export Control (BAFA) as control authority. If the tracing request clearly indicates that the weapon in question carries a federal or state authority marking (cf. § 2.8.1 supra), the registers enumerated in § 2.8.5 will be consulted. If the enquiries reveal that a seized firearm was sold to a foreign country or that it was produced by a foreign manufacturer, the request for ascertaining the sales history of a firearm is sent to the Federal Criminal Police Office. In such cases the Federal Criminal Police Office functions as an intermediary between our State Police and the foreign police services if the firearm concerned was produced, sold or purchased in a foreign country.

2.8.6.3 Federal Customs Administration

The customs authorities address all requests concerning identification of sale channels of illicit SALW to the Federal Criminal Police Bureau.

2.9 Disarmament, Demobilization and Reintegration (DD&R)

Please describe (i) any disarmament, demobilization and reintegration (DD&R) programs your country has developed and implemented, including the effective collection, control, storage and destruction of SALW, (ii) how your country has addressed the special needs of children affected by armed conflict, in particular the reunification with their family, their reintegration into civil society, and their appropriate rehabilitation, and (iii) any DD&R programs or activities that your country has supported.

UNPoA II: 21, II:22, II:30, II:34

Afghanistan (duration 2004 - ; overall budget € 3.000.000)

Since 2004, Germany has been supporting the DD&R and DIAG processes in Afghanistan by co-financing the disposal and destruction of surplus weapons and ammunition.

Angola (duration 2003-2009, overall budget: € 11.990.332)

Germany supports the social and economic reintegration of ex-combatants and their families in Angola. Through the Instituto de Reintegração Sócio-Profissional para Ex-militares (IR-SEM) Germany contributes to the World Bank-led Angola Demobilization and Reintegration Programme (ADRP). The reintegration of ex-combatants is supported on the local level

through socio-economic development projects and the strengthening of local government administration.

Burundi (duration 2003-2010, overall budget: € 15.9400.000)

Germany supports projects for the reintegration of ex-combatants, internally displaced persons (IDPs) and returning refugees in Burundi. The German contribution consists of four main components: empowerment of communal reintegration structures, revitalization of agricultural production, income generation and rehabilitation of infrastructure.

Cambodia (duration 2007-2009, overall budget: € 1.615.000)

Germany supports the Royal Government of Cambodia in its work with regard to SALW control issues with a focus on stockpile management and the destruction of conventional ammunition stockpiles in surplus.

Congo, Democratic Republic (duration: 2005-2011, overall budget: € 12.000.000)

Germany supports the social and economic reintegration of children and youth formerly associated with fighting forces in the province Maniema in DRC with 3,5 Mio. Euro (technical assistance) as well as with funds for the reintegration of ex-combatants amounting to 8,5 Mio Euro (until October 2008, financial assistance) for work-intensive infrastructure projects.

Greater Great Lakes Region (duration 2003-2009, overall budget: € 12.900.000)

Germany contributes to the Trust Fund of the World Bank led Multi-Country Demobilization and Reintegration Programme (MDRP) for the Greater Great Lakes Region amounting to 12,9 Mio. Euro. Germany also commits funds to the project "Combating the illicit proliferation of small arms and light weapons" which is implemented in the frame of the support of the Conference process of the Great Lakes Region (2004-2011) / 7.5 Mio Euro.

Senegal (2004 – 2015, budget for the second phase (2007-2010): € 11.800.000)

Germany supports the peace building and socio-economic development program in the Casamance region. The program promotes local peace initiatives and measures to reintegrate returnees. It also provides support in reconstructing the social and economic infrastructure, as well as for agricultural production and other sources of income.

Nepal (duration 2007 – 2010, overall budget: € 2.300.000)

In the middlewest of Nepal, Germany supports the socio-economic rehabilitation and reintegration program of ex-combatants/IDPs/refugees and the receiving communities in Rukum and Rolpa districts. The project's main approaches are to create basic social and economic infrastructure and to improve household incomes in the agricultural and non-agricultural sectors. The program contributes to the implementation of the 2006 peace-agreement.

Nepal (duration 2007 – 2010, overall budget: € 5.000.000)

Since 2007 Germany is implementing the project "Support for measures for the peace process" in the south of the country. The project provides basic services like water supply, sanitation and health care to interned Maoist fighters and the inhabitants of the surrounding communities.

Liberia (2005-2007, overall budget € 10.750.000)

Germany supports the national Demobilization and Reintegration Program (DDRP). The programme provides psychosocial assistance to victims of war related sexual abuse in Liberia and supports the reintegration of homecoming refugees and ex-combatants through labour intensive rehabilitation of infrastructure.

Rwanda (duration 2003-2007, overall budget: € 8.773.000)

Germany supports the Rwanda Demobilization and Reintegration Commission (RDRP) and the process of social reintegration as well as medical rehabilitation of ex-combatants in Rwanda.

2.10 Awareness-raising

Please describe (i) any public awareness and confidence-building programs on the problems and consequences of the illicit trade in SALW in all its aspects that your country has developed and implemented (including the public destruction of surplus weapons and the voluntary surrender of SALW) and (ii) any education and public awareness programs on the problems of the illicit trade in SALW in all its aspects that your country has encouraged.

UNPoA II:20, II:41

In Germany, both media and the educational system take due note not only of the problems of illicit trade in SALW, but also of the development impact connected with SALW in particular. Germany was the first participating State in the OSCE who published its entire Information Exchange Pursuant to the OSCE Document on Small Arms and Light Weapons Report in the Internet—an example of transparency later followed by other participating States.

3 Regional Level

3.1 Legally Binding Instruments

- 3.1.1 Has your country been involved in negotiations for the conclusion of legally binding instruments aimed at preventing, combating and eradicating the illicit trade in SALW in all its aspects?

UNPoA II:25

To give only a few examples, Germany participated in the elaboration of the Council Joint Action 2002/589/CFSP of July 12, 2002 with regard to the European Union's contribution to combating the destabilizing accumulation and spread of small arms and light weapons.⁴ Germany participated in the negotiations of the Protocol Against the Illicit Manufacturing of and Trafficking in Firearms, Their Parts and Components and Ammunition, supplementing the United Nations Convention Against Transnational Organized Crime (Firearms Protocol) of 31 May 2001 which entered into force on 3 July 2005. Finally, Germany continues to be actively engaged in negotiations relating to the various issues addressed in the UN Programme of Action, taking a particular interest in stockpile management issues.

⁴ □ Official Journal of the European Communities L 191/1 of July 19, 2002.

- 3.1.2 Where such instruments exist, please describe the steps your country has taken to ratify and fully implement them.

UNPoA II:25

Germany fully supports and implements the EU Joint Action 2002/589/CFSP. The process of ratification of the UN Firearms Protocol is under way.

3.2 Moratoria and Regional Action Programs

Please give details of any support your country has given moratoria or similar initiatives on the transfer and manufacture of SALW, and/or regional action programs to prevent, combat and eradicate the illicit trade in SALW in all its aspects (including cooperation with States concerned in the implementation of these initiatives).

UNPoA II:26

Germany fully supports and implements in her national export control decisions U.N. Security Council resolutions regarding export of SALW to countries subject to an (arms) embargo as well as EU Common Positions regarding the export of SALW to specific destinations. Germany also respects regional moratoria and is interested in a close cooperation with countries to implement them in the framework of the Wassenaar Arrangement.

3.3 Regional Cooperation

- 3.3.1 Please describe any involvement your country has had in the establishment of sub regional or regional mechanisms with a view to preventing, combating and eradicating the illicit trade in SALW across borders (in particular trans-border customs cooperation and networks for information-sharing among law enforcement, border and customs control agencies).

UNPoA II:27

Germany actively supported the introduction of effective export control mechanisms in acceding and associated countries in Eastern Europe and took part in both bi- and multilateral consultations. In that context, particular attention has been given to the SALW issue, including the elaboration and promulgation of new appropriate laws and the creation of an atmosphere necessary for effective law enforcement. At sub regional level, the Federal Customs Administration is involved in preventing and combating illicit cross-border trafficking in SALW by carrying out selective checks on flows of goods not motivated by any concrete suspicion. These checks are carried out in particular by the Border Clearance and Surveillance Services and the Mobile Control Groups. At regional level, the close cooperation between the Customs Investigation Service and the French customs administration merits to be highlighted. It includes regular special checks carried out jointly and aimed exclusively at combating trafficking in SALW. These special checks have proved their worth over a period of many years. The exchange of information between German, French and Austrian customs authorities is very extensive. The customs investigation services of these countries exchange intelligence on trafficking in SALW by means of prompt and unbureaucratic provision of information.

- 3.3.2 Please describe any initiatives your country has undertaken to encourage regional and subregional action on illicit trade in SALW in all its aspects in order to, as appropriate, in-

roduce, adhere, implement or strengthen relevant laws, regulations and administrative procedures.

UNPoA II:28

Germany has in recent years paid particular attention to the issue of effective and efficient management and security of national stockpiles of conventional arms and ammunition, as explained in the introductory remarks. The issue of conventional ammunition stockpiles in surplus has been a major concern in this respect, since conventional ammunition contains explosive materials. The main focus of regional and subregional activities relates to stockpile management and security.

Germany continues to support the intensification of the exchange, between the States participating in the Wassenaar Arrangement, of information on conventional weapons and especially SALW, the latter having been identified as weapons of choice of terrorists.

Germany supports the Southern African Development Community (SADC) in the implementation of the SADC Protocol on the Control of Firearms, Ammunition and Other Related Material. As part of this cooperation Germany has deployed an advisor on peace and security issues to support the establishment of a Regional Focal Point at the SADC Secretariat. The project includes the following components: harmonization of policies and legislation, capacity building, training of law enforcement agencies and cooperation with civil society actors.

Germany supports the development of a political, legal and institutional framework within the East African Community to control the uncontrolled proliferation of SALW. Components of the project with the Secretariat of the East African Community (EAC) include organisational development to set up a Regional Focal Point on Small Arms Control, harmonization of policies and legislation, training, development of systematic approaches to assess the problem of SALW, and education and awareness raising in cooperation with civil society organisations in EAC member states.

Germany cooperates with the League of Arab States (AL) by providing assistance to SALW-related work at various levels. Support was given for a meeting of SALW focal points from the countries of the League. The translation of OSCE documents on SALW issues into the Arabic language continued. Study visits of SALW Focal Points from the League of Arab States and the Secretariat to Berlin, Vienna (OSCE) and Geilenkirchen (German Armed Forces Verification Center) were organized in 2007, 2008 and 2009 to intensify exchange and dialogue on various aspects of the UN PoA..

4 Global Level

4.1 International Instruments Against Terrorism and Organized Crime

What existing international legal instruments against terrorism and transnational organized crime has your country ratified or acceded to?

UNPoA II:38

Germany strongly supports the establishment of an international legal framework to combat all forms of terrorism. She has, thus, ratified the following treaties, including all 13 U.N. Conventions and Protocols concerning international terrorism:

- (i) Convention on Offences and Certain Other Acts Committed on Board Aircraft, signed at Tokyo on September 14, 1963;
- (ii) Convention for the Suppression of Unlawful Seizure of Aircraft, signed at The Hague on December 16, 1970;
- (iii) Convention for the Suppression of Unlawful Acts against the Safety of Civil Aviation, signed at Montreal on September 23, 1971;
- (iv) Convention on the Prevention and Punishment of Crimes against Internationally Protected Persons, including Diplomatic Agents, adopted by the General Assembly of the United Nations on December 14, 1973;
- (v) International Convention against the Taking of Hostages, adopted by the General Assembly of the United Nations on December 17, 1979;
- (vi) Convention on the Physical Protection of Nuclear Material, signed at Vienna on March 3, 1980;
- (vii) Protocol on the Suppression of Unlawful Acts of Violence at Airports Serving International Civil Aviation, supplementary to the Convention for the Suppression of Unlawful Acts against the Safety of Civil Aviation, signed at Montreal on February 24, 1988;
- (viii) Convention for the Suppression of Unlawful Acts against the Safety of Maritime Navigation, done at Rome on March 10, 1988;
- (ix) Protocol for the Suppression of Unlawful Acts against the Safety of Fixed Platforms Located on the Continental Shelf, done at Rome on March 10, 1988;
- (x) Convention on the Marking of Plastic Explosives for the Purpose of Detection, signed at Montreal on March 1, 1991;
- (xi) International Convention for the Suppression of Terrorist Bombings, adopted by the General Assembly of the United Nations on December 15, 1997;
- (xii) International Convention for the Suppression of the Financing of Terrorism, adopted by the General Assembly of the United Nations on December 19, 1999;
- (xiii) International Convention for the Suppression of Acts of Nuclear Terrorism, adopted (and signed by Germany) at New York on 13 April 2005.

Germany has ratified the following conventions and protocols against transnational organized crime:

- (i) United Nations Convention against Transnational Organized Crime of November 15, 2000
- (ii) Protocol to Prevent, Suppress and Punish Trafficking in Persons, Especially Women and Children, supplementing the United Nations Convention against Transnational Organized Crime of November 15, 2000;
- (iii) Protocol against the Smuggling of Migrants by Land, Sea and Air, supplementing the United Nations Convention against Transnational Organized Crime of November 15, 2000.

Germany has signed the following conventions and protocols against transnational organized crime:

- (i) UN Convention against Corruption of October 31, 2003;

(ii) Protocol against the Illicit Manufacturing of and Trafficking in Firearms, Their Parts and Components and Ammunition, supplementing the United Nations Convention against Transnational Organized Crime of May 31, 2001, and is actively working on its ratification.

Germany has, as a Member State of the Council of Europe, further ratified the following treaties relevant in the fight against terrorism and organized crime:

- (i) European Convention on Mutual Assistance in Criminal Matters, signed at Strasbourg on April 20, 1959;
- (ii) European Convention on the Suppression of Terrorism, signed at Strasbourg on January 27, 1997 and the Protocol amending the European Convention on the Suppression of Terrorism on May 17, 1978
- (iii) Additional Protocol to the European Convention on Mutual Assistance in Criminal Matters, signed at Strasbourg on March 17, 1978;
- (vi) Convention on Laundering, Search, Seizure and Confiscation of the Proceeds from Crime, signed at Strasbourg on November 8, 1990.

Germany has further signed the following conventions and protocols:

- (i) Convention on Cyber crime on November 23, 2001;
- (ii) Additional Protocol to the Convention on Cyber crime on January 28, 2003;
- (iii) Council of Europe Convention on the Prevention of Terrorism on October 24, 2006.

4.2 International Cooperation and Assistance

4.2.1 Please give details of any assistance, including technical and financial assistance, your country has provided for purposes of supporting the implementation of the measures to prevent, combat and eradicate the illicit trade in SALW in all its aspects as contained in UNPoA.

UNPoA III:3, III:6, III:10, III:14

From 2001 – 2008 the German Government established the sectoral project "Development Cooperation and Small Arms Control (decosac)". One objective of the project was to develop and test instruments for small arms control in development cooperation. The overall budget of decosac was 3.452.000 Euro. In July 2008 the sectoral project 'Development Cooperation and Small Arms Control' has been merged with the sectoral projects on 'Crisis Prevention' and 'Security Sector Reform' into the sectoral program on 'Peace and Security' (duration 2008 – 2014, budget 2008 – 2011: 5.000.000). The 'Peace and Security' program deals with SALW related issues within the scope of Armed Violence Reduction and Prevention.

Germany also supports UNDP's Thematic Trust Fund for Crisis Prevention and Recovery and has earmarked her contributions to the service lines for small arms and security sector reform. In 2005 and 2006, German contributions to these service lines amounted to 1.323.500,00 Euro and 1.286.800,00 Euro respectively. Further 2.000.000 Euro to these service lines has been disbursed in 2007. Germany expects to be in the position to continue this support in future years.

- 4.2.2 Please describe any initiatives your country has undertaken to enhance mutual legal assistance and other forms of cooperation in order to assist investigations and prosecutions in relation to the illicit trade in SALW in all its aspects.

UNPoA III:13

In a broader sense, Germany has promoted the cause to facilitate legal action against the illicit trade in SALW by concluding bilateral agreements with a number of countries which contain clauses on preventing, combating and eradicating trafficking of weapons.

- 4.2.3 Please give details of any assistance your country has provided to combat the illicit trade in SALW linked to drug trafficking, transnational organized crime and terrorism.

UNPoA III:15

Detailed analysis and evaluation of criminal activities implying illicit trade in SALW in Germany suggest that the often assumed linkage to drug trafficking, transnational organized crime and terrorism cannot readily be established as to SALW-related crimes committed in Germany. Endeavors made by Germany focus therefore on respective assistance granted to neighboring European countries. In the framework of the Stability Pact for South Eastern Europe, Germany has engaged in an intensive cooperation, at police and customs level, with different countries in the region, hereby mainly focusing on the training and specialization of border police forces as prime authorities to combat illicit trafficking in SALW.

- 4.2.4 Please give details of your country's cooperation with Interpol for the purpose of identifying those groups and individuals engaged in the illicit trade in SALW in all its aspects.

UNPoA II:37

Germany is closely cooperating with Interpol for the purpose of identifying those groups and individuals engaged in the illicit trade in SALW, if required in the framework of individual criminal investigations. In one case, the government of another State actively combating illicit handling of SALW has forwarded a voluminous tracing request to Germany directly, and not through Interpol, on the ground that the request did not emerge from individual criminal investigations.

- 4.2.5 Please give details of your country's use and support of Interpol's International Weapons and Explosives Tracking System database (including providing relevant information on the illicit trade in SALW).

UNPoA III:9

IWETS was re-named to "Interpol Weapons Electronic Tracing System", which is being developed and tested by Interpol Lyon and the USA (ATF). As soon as a workable version exists, it will be put at the disposal of the member states.

- 4.2.6 Please give details of your country's cooperation with the U.N. system to ensure the effective implementation of arms embargoes decided by the U.N. Security Council in accordance with the U.N. Charter.

UNPoA II:32

Both in her national decision-making process related to all export and brokering control matters and in the practice of her courts, Germany fully supports and implements arms embar-

goes decided by the U.N. Security Council in accordance with the U.N. Charter. As has been emphasized in § 2.3.3 and § 2.6.1.1 supra, the competent authorities will inevitably dismiss license applications if there is ground to believe, in the individual case, that the envisaged activity would violate an arms embargo imposed by the U.N. Security Council in accordance with the U.N. Charter. While arms embargoes, in principle, do not require transformation into municipal law, in a number of cases more comprehensive arrangements are applied and implemented in accordance with relevant EC Council Regulations. Further, section 69a to 69o of the Foreign Trade and Payments Ordinance contains an additional number of specific embargo- or destination-related prescriptions.⁵ The terms and provisions of the relevant embargo are transposed into practice by turning down any license applications concerning the export of such goods to embargoed destinations. In Germany, contravening embargoes imposed by the United Nations Security Council, for instance by exporting SALW to embargoed destinations, is considered a serious crime and thus consistently prosecuted. Pursuant to the first phrase of section 34(4) of the Foreign Trade and Payments Act, illegal trade in SALW violating such an arms embargo yields imprisonment not shorter than 2 years. In minor (less serious) cases, the custodial sanction may range between 3 months and 5 years; second phrase of section 34(4) of the Foreign Trade and Payments Act.

- 4.2.7 Please describe any steps your country has taken in cooperation with other states, or regional or international organizations, to develop common understandings of the basic issues and the scope of the problems related to illicit brokering in SALW.

UNPoA II:39

Germany has many years' experience with the the practical implementation of brokering controls for war weapons including SALW. In the course of discussions on arms brokering controls within the framework of the OSCE, the Wassenaar Arrangement and the EU Germany shared this experience with her partners. The brokering documents adopted by these fora reflect, to a considerable extent, this input. Moreover, Germany participated in the broad based consultations the United Nations organized on brokering. Germany has actively accompanied the deliberations of the UN Group of Governmental Experts on illicit brokering in SALW.

Germany participates in the OECD DAC CPDC (Conflict Peace & Development Cooperation) Network (from December 2008 on OECD DAC INCAF – International Network on Conflict and Fragility) and supports actively the CPDC/INCAF approach on Armed Violence Reduction and Prevention (AVR). AVR is an emerging set of practices that builds on existing frameworks, approaches and lessons learned in areas such as conflict prevention, peace building, crime prevention and public health including SALW Control; SSR, Crime/Drug Prevention. Germany co-finances an OECD INCAF programming note on AVR and youth violence which will be published in 2010.

⁵ □ Violations against section 69g of the *Foreign Trade and Payments Ordinance* do not constitute criminal, but rather administrative offenses, rendering, as a rule, administrative fines.

4.3 Cooperation with Civil Society and Nongovernmental Organizations

Please give details of cooperation with civil society and nongovernmental organizations in activities related to the prevention, combat and eradication of the illicit trade in SALW in all its aspects, at the national, regional and global levels.

UNPoA II:20, 40, 41; III.2, 18

The Federal Foreign Office is chairing regular meetings of representatives from the different ministries with responsibility for SALW issues, including NGO and industry representatives to coordinate SALW related policy issues.

Germany is supporting activities from NGO's which further the implementation of the UN PoA, including the elaboration of studies on certain aspects of the illicit trade in SALW or awareness raising in certain countries of concern.

4.4 Information Exchange

- 4.4.1 Please describe any steps taken by your country to exchange information on national marking systems on SALW.

UNPoA III:12

For detailed technical information in English on the German system of marking of arms and weapons see Annex D as well as cf. § 2.8.1 supra.

- 4.4.2 Please give details of any information on, inter alia, SALW confiscated or destroyed within national jurisdiction, or other relevant information such as illicit trade routes and techniques of acquisition, that your country has submitted to relevant regional and international organizations.

UNPoA II:23

Detailed information on SALW confiscated or destroyed both within the German jurisdiction and, with the assistance of the Federal Armed Forces in the context of peace-keeping missions overseas, is regularly submitted to the OSCE with the "Information Exchange Pursuant to the OSCE Document on Small Arms and Light Weapons—Annual Report". The annual statistics of the Federal Criminal Police Bureau include the number of seizures made by the Customs Investigation Service (cf. §2.5.6.4 supra).

4.5 Training, Capacity-Building, Research

- 4.5.1 Please describe any initiatives your country has undertaken to enhance cooperation and exchange of experience and training among competent officials, including customs, police, intelligence and arms control officials, at the national, regional and global levels in order to combat the illicit trade in SALW in all its aspects.

UNPoA III:7

As mentioned under 3.3.2, the German Government is supporting the Southern African Development Community (SADC), the East African Community (EAC) and the League of Arab States in their efforts to stem the illicit trade and proliferation of SALW. Particularly, trainings for law enforcement agencies on SALW issues and capacity building measures of

stakeholders such as the police or civil society organisations are envisaged or carried out. Detailed cooperation programmes with regard to stockpile management issues take part in cooperation with ECOWAS and RECSA.

- 4.5.2 Please describe any regional and international programs for specialist training on small arms stockpile management and security that your country has developed or supported.

UNPoA III:8

In the framework of the Stability Pact for South Eastern Europe, the Federal Police have responded to demands from different countries in the region so as to cooperate in the fields of training and specialization of border police forces as prime authorities to combat illicit trafficking in SALW. Germany has provided financial and expert support to seminars on border security, SALW marking and stockpile management, conducted under the auspices of the OSCE, in cooperation with UNDP/SEESAC and in the frame of RACVAIC –Centre for Security Cooperation.

- 4.5.3 Please give details of any action-oriented research aimed at facilitating greater awareness and better understanding of the nature and scope of the problems associated with the illicit trade in SALW in all its aspects that your country has developed or supported.

UNPoA III:18

Since 2004, Germany has sponsored a project by the Bonn International Centre for Conversion (BICC) that aims at the development of a range of ready-to-teach courses on various aspects of small arms action for a variety of target groups in developing countries. Already in 2005, 300.000 € have been appropriated for the project. In 2008, the main focus has been the development of a training module on marking and tracing of SALW and their ammunition. The project is accessible at www.tresa-online.org.

Since 2006 Germany sponsors studies of Small Arms Survey on certain aspects of the illicit trade in SALW, especially the trade of ammunition which are published in the yearbook of Small Arms Survey or separate publications.

ANNEX A POLITICAL PRINCIPLES GOVERNING THE EXPORT OF WAR WEAPONS AND OTHER MILITARY EQUIPMENT, ADOPTED ON JANUARY 19, 2000

The Government of the Federal Republic of Germany, desiring

- to pursue a restrictive policy on arms exports,
- with regard to the international and statutory obligations of the Federal Republic of Germany regarding exports of war weapons and other military equipment to countries,
- through the restriction and control of such exports to contribute to safeguarding peace, preventing the threat or use of force, securing respect for human rights and promoting sustainable development in all parts of the world,
- hence to take account also of decisions adopted by international institutions with a view to disarmament and designed to restrict the international arms trade,
- to press for such decisions to be made legally binding at the international as well as at the European level,

has modified its principles for the export of war weapons and other military equipment as follows:

I. General Principles

1. The Federal Government's decisions regarding the export of war weapons⁶ and other military equipment⁷ are made in accordance with the provisions of the *War Weapons Control Act* and the *Foreign Trade and Payments Act* as well as the *EU Code of Conduct for Arms Exports* adopted by the European Council on June 8, 1998, and such arrangements as may be agreed subsequently as well as the *Principles Governing Conventional Arms Transfers* adopted by the Organization for Security and Cooperation in Europe (OSCE) on November 25, 1993. The criteria laid down in the *EU Code of Conduct for Arms Exports* are an integral part of these Policy Principles. The standards stipulated in the Code of Conduct will be superseded by any more stringent standards that may be derived from the following principles:
2. The issue of respect for human rights in the countries of destination and end-use is a key factor in deciding whether or not to grant licenses for the export of war weapons and other military equipment.
3. On principle export licenses for war weapons and other military equipment will not be granted where there are reasonable grounds to suspect that they will be used for internal repression as defined in the *EU Code of Conduct for Arms Exports* or the sustained and systematic abuse of human rights. In this context the assessment of the human rights situation in the recipient country is an important factor to be considered.
4. Such assessments will take into account the views of the European Union, the Council of Europe, the United Nations (U.N.), the OSCE and other international bodies. Reports issued by international human rights organizations will also be taken into consideration.
5. The end-use of war weapons and other military equipment must be definitively determined.

⁶ □ Weapons (complete weapons as well as components classed separately as weapons) listed in the *War Weapons Schedule* (Annex to the *War Weapons Control Act*).

⁷ □ Goods specified in Part I section A of the *Exports Schedule* (Annex to the *Foreign Trade and Payments Act*) with the exception of war weapons.

II. NATO Countries,⁸ EU Member States, Countries with NATO-Equivalent Status⁹

1. The export of war weapons and other military equipment will be geared to the security interests of the Federal Republic of Germany with regard to the Alliance and the European Union. In principle, such export will not be restricted unless in specific cases this is warranted on particular political grounds.
2. Cooperative ventures in this area should be in the interest of the Alliance and/or European policy. In the case of co production projects covered by intergovernmental agreements with countries referred to in this section, these arms export principles will be given practical effect as far as possible. While mindful of its special interest in its cooperation standing, the Federal Government will not forgo any opportunities it may have to influence export projects envisaged by its cooperation partners (Section II[3]).
3. Before concluding any cooperation agreement, a timely joint assessment of its export policy implications is to be made. To give effect to its arms export policy principles, the Federal Government reserves the right by way of consultations to object to particular export projects envisaged by its cooperation partners. All new cooperation agreements should therefore aim in principle to incorporate a consultations procedure enabling the Federal Government to raise effectively any objections it might have to exports envisaged by its partner country. In doing so the Federal Government will seek, in the light of the human rights criterion, to strike a balance between its interest in cooperation and its fundamentally restrictive arms export policy.
4. Before any exports of war weapons or other military equipment involving German components take place, the Federal Foreign Office, the Federal Ministry of Economics and Technology and the Federal Ministry of Defense, in conjunction with the Federal Chancellery, will evaluate whether in any specific case the relevant conditions for initiating such consultations exist. The Federal Government will raise objections—generally following consideration of the matter by the Federal Security Council—against such exports involving the use of German components in the following cases:
 - exports to countries involved in an armed conflict, unless such conflict is covered by Article 51 of the UN Charter,
 - exports to countries where an outbreak of armed conflict is imminent or where exports may stir up, perpetuate or exacerbate latent tensions and conflicts,
 - exports where there are reasonable grounds to suspect that they may be used for internal repression as defined by the EU Code of Conduct for Arms Exports or the sustained and systematic abuse of human rights,
 - exports that would impair the vital security interests of the Federal Republic of Germany,
 - exports that would impose such a strain on relations with third countries that even Germany's own interest in the cooperative venture and in maintaining good relations with its cooperation partner must rank second.

⁸ □ Area of application of Article 6 of the NATO Treaty.

⁹ □ Australia, Japan, New Zealand, Switzerland.

Objections will not be raised if in the light of the considerations outlined in Section III(4) to (7) below licenses for the export of direct deliveries of war weapons and other military equipment are likely to be granted.

5. In the case of cooperative ventures between German companies and companies in countries referred to in Section II above not covered by intergovernmental agreements, supplies of components will, as with direct deliveries of war weapons and other military equipment, in principle not be restricted. The Federal Government will, however, as in the case of cooperative ventures covered by intergovernmental agreements, bring its influence to bear in the matter of exports resulting from cooperative ventures between commercial companies.

To that end it will require German cooperative venture partners to enter a contractual obligation that, should they supply components of a quantity or type that could be relevant to the manufacture of war weapons, they will inform the Federal Government in good time as to their partners export intentions and seek legally binding arrangements on end-use.

6. In the case of German supplies of components (separate components or subsystems) that constitute war weapons or other military equipment, the partner country is in terms of exports law both purchaser and user. Where such components are built into a weapons system as fixed features, that process in terms of exports law makes the partner country the country of origin of the goods in question.

III. Other Countries

1. A restrictive policy will be pursued regarding exports of war weapons and other military equipment to countries other than those covered by Section II. Notably the development of additional, specifically export-oriented must be avoided. The Federal Government will not take the initiative to privilege any specific country or region.
2. Export licenses for war weapons (subject to licensing under the *War Weapons Control Act* and the *Foreign Trade and Payments Act*) will not be granted unless in a specific case this is exceptionally warranted on particular foreign and security policy grounds, having due regard to Alliance interests. Labor policy considerations must not be a decisive factor.
3. Export licenses for other military equipment (subject to licensing under the *Foreign Trade and Payments Act*) will be granted only where such exports will not prejudice interests that German law on foreign trade and payments serves to protect, namely, security, peace among the nations and Germany's foreign relations.
The protection of these interests takes priority over economic interests as defined in Section 3(1) of the *Foreign Trade and Payments Act*.
4. Export licenses pursuant to the *War Weapons Control Act* and/or the *Foreign Trade and Payments Act* will not be granted where the internal situation in the country concerned precludes such action, e.g. in the case of armed conflict or where there are reasonable grounds for suspecting such exports may be used for internal repression or the sustained and systematic abuse of human rights. In this context the human rights situation in the recipient country is a major factor to be considered.

5. No licenses will be granted for the export of war weapons and other military equipment related to war weapons¹⁰ to countries—
 - involved in armed conflict or where armed conflict is imminent,
 - where the outbreak of armed conflict is imminent or where such exports would stir up, perpetuate or exacerbate latent tensions and conflicts.Exports to countries involved in external armed conflicts or where there is a danger such conflicts may erupt are therefore ruled out on principle except in cases covered by Article 51 of the U.N. Charter.
6. Decisions on whether to grant export licenses for war weapons and other military equipment will take into account whether sustainable development in the recipient country is being seriously impeded by excessive arms spending.
7. Also to be taken into account is the recipient country's conduct in terms of whether it—
 - supports and promotes terrorism and international organized crime,
 - complies with international obligations, especially renunciation of the threat or use of force, including obligations under humanitarian law on international or non-international conflicts,
 - has assumed obligations in the area of non-proliferation and other aspects of arms control and disarmament, notably by signing, ratifying and implementing the arms control and disarmament arrangements specified in the *EU Code of Conduct for Arms Exports*,
 - supports the U.N. Register of Conventional Arms.

IV. Definitive Determination of End-Use

1. Export licenses for war weapons and other military equipment will be granted only on the basis of prior knowledge of definitive end-use in the country of final destination.
This will generally require a written assurance by the end-user as well as other appropriate documentation.
2. Export licenses for war weapons or other military equipment of a quantity and type relevant to war weapons may be granted only on the presentation of governmental end-use certificates that preclude re-exports without prior authorization. This applies *mutatis mutandis* to any other military equipment related to war weapons exported in connection with a manufacturing license. For the export of such equipment used for the manufacture of war weapons definitive end-use certificates must be furnished.
Stringent standards are to be applied in assessing whether the recipient country is capable of carrying out effective export controls.
3. War weapons and other military equipment relevant to war weapons may only be re-exported to third countries or transferred inside the EU Internal Market with the written approval of the Federal Government.
4. A recipient country that, in breach of an end-use certificate, authorizes or does not seek to prevent or sanction the unauthorized re-export of war weapons or other military equipment relevant

¹⁰ □ Plant and documentation for the manufacturer of war weapons.

to war weapons will on principle, as long as such conditions persist, be excluded from receiving any further deliveries of war weapons or other military equipment related to war weapons.

V. Arms export report

The Federal Government will submit to the German *Bundestag* an annual report on the principle and practice of its arms exports policy listing, with details of the relevant legislation, the export licenses for war weapons and other military equipment it has granted over the past year.

ANNEX B ANALYSIS AND EVALUATION OF INFORMATION AVAILABLE TO THE FEDERAL CRIMINAL POLICE BUREAU ON THEFTS, LOSSES AND SEIZURES OF SALW IN 2009

B.1 Introductory Remark

Federal statistics on weapons-related criminality focus on the category of crimes and on seizures. It does, however, not cover data on the number of suspects, accused or convicted persons.

B.2 Thefts and Losses

In 2009 no SALW were reported stolen and two assault rifles were registered as lost.

B.3 Seizures

In 2009, 123 cases of SALW seizures have been registered in the Federal Criminal Police Bureau's central database, comprising the following quantities:

SALW Seizures in 2009

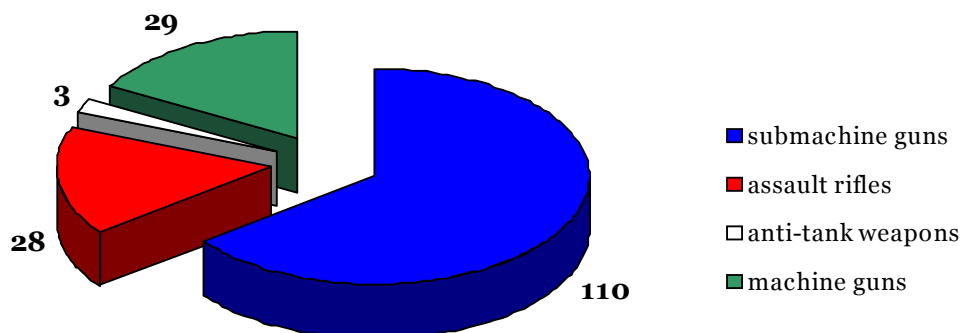

Six of the 110 seized submachine guns and one of the 28 seized assault rifles were confiscated in the course of investigations relating to criminal offences according to the German Penal Code.

In 2009, 64 submachine guns, 7 machine guns, 17 assault rifles and 2 anti-tank weapon were seized which could doubtlessly be related to a specific country of manufacture. 80 pieces of the total amount of 170 seized firearms could, however, not unambiguously be related to a specific country of production:

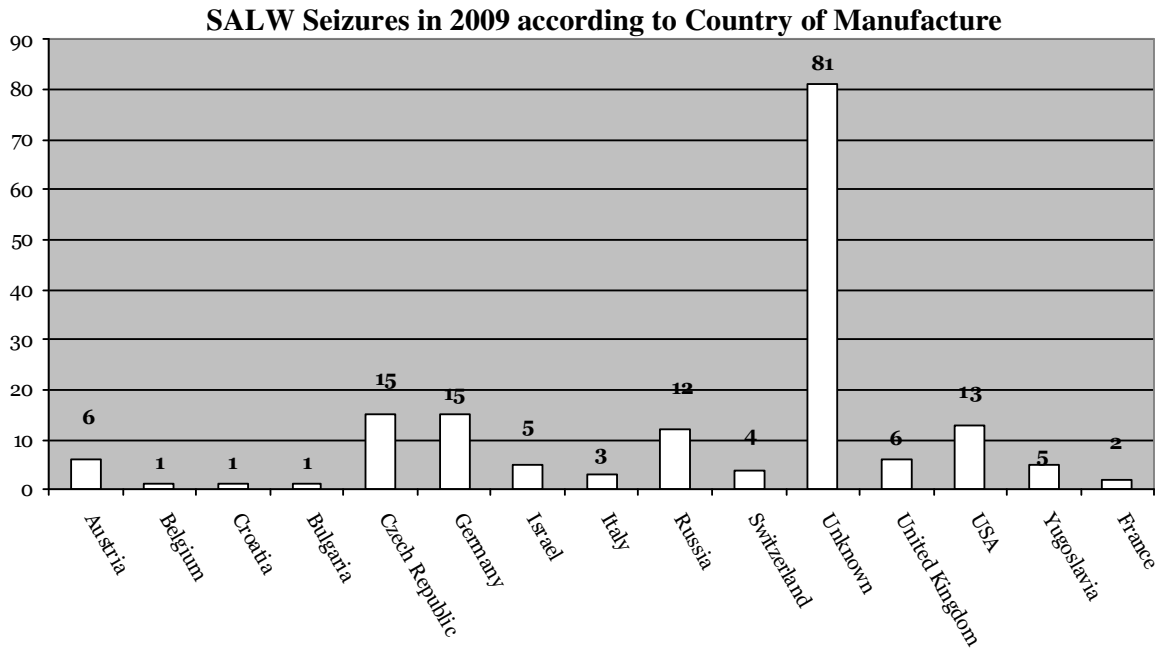

The majority of the illegally used and seized SALW of international producers were modern military items, currently used in armed forces of several countries. The seized weapons of German origin were prevailing models developed before 1945. The results of the evaluation prove that the German legislation aiming at the control of war weapons and war material is effective and strict. Weapons of German origin do not play a dominant part in the field of criminality. It is especially weaponry manufactured abroad and illicitly brought into Germany which constitutes the major problem.

B.4 Illicit Trafficking

3 of the a/m 170 SALW firearms were seized in connection with illicit trafficking.

B.5 Illicit Manufacture

None of the a/m 170 SALW firearms were seized in connection with illicit manufacture.

ANNEX C NUMBER OF FEDERAL ARMED FORCES SALW DESTROYED IN THE PERIOD 2005-2009

In the period 2005 to 2009 the Federal Armed Forces have demilitarized the following numbers of SALW in the listed categories:

Year	2005	2006	2007	2008	2009
Small arms					
Revolvers and self-loading Pistols	4.774	9.519	7.437	23.830	8.750
Rifles and carbines	0	0	0	0	0
Sub-machine guns	12.323	25.101	22.087	7.885	6.319
Assault rifles	110.044	120.218	39.231	32.945	45.197
Light machine guns	1.418	0	0	179	7.815
Light weapons					
Heavy machine guns	0	0	0	0	0
Hand-held, under-barrel and mounted grenade launchers	2	2.896	821	295	7.444
Portable anti-aircraft guns	0	0	0	0	0
Portable anti-tank guns	0	0	0	0	0
Recoilless rifles	0	0	0	0	0
Portable launchers of anti-tank missile and rocket systems	3.864	4.330	9.874	5.667	1.034
Portable launchers of anti-aircraft missile systems	0	0	0	0	0
Mortars of calibers less than 100 mm	0	0	0	0	0
Total	132.425	162.064	79.450	70.801	76.559

Since 1990 Germany has demilitarized 2.303.252 SALW about all categories.

ANNEX D LOCATION AND SAMPLE OF MARKS

Sample proof firing mark



Location of marks

1.1.4 Kennzeichnungsstellen

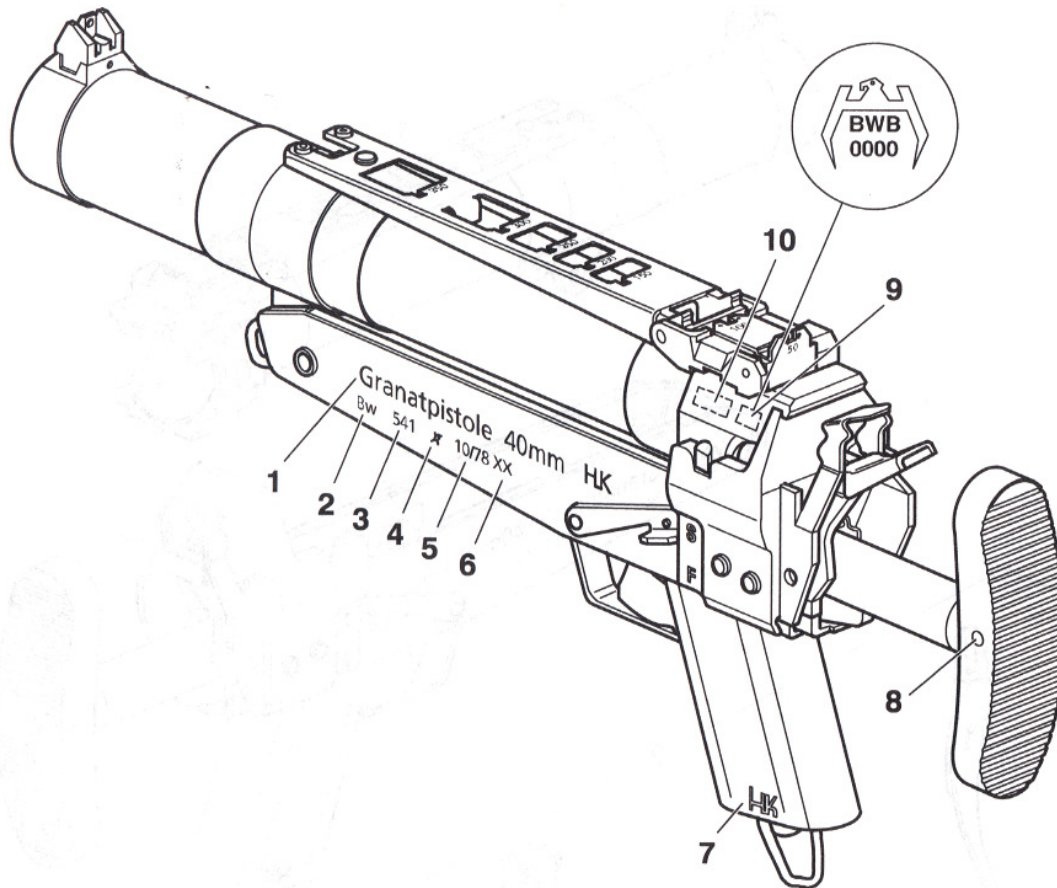

- 1 Type designation
- 2 Property stamp
- 3 Manufacturing no.
- 4 Asterisk for system maintenance center
- 5 Month/year of manufacturing (right-hand side: month/year of major repair, monogram of maintenance center)
- 6 Proof firing stamp/inspection stamp
- 7 Manufacturer's stamp
- 8 Mark for modified catch
- 9 Proof firing stamp
- 10 Last 3 digits of item no.

ABBREVIATIONS

CVAP	Cambodian Veterans Assistance Program
DD&R	Disarmament, Demobilization and Reintegration
DIAG	Disbandment of Illegal Armed Groups
EAC	East African Community
ECOWAS	Economic Community of West African States
IWETS	International Weapons and Explosives Tracking System (an Interpol database)
MDRP	Multi-Donor Demobilization and Reintegration Program
NGO	non-governmental organisation
OSCE	Organization for Security and Cooperation in Europe
SADC	Southern African Development Community
SALW	Small arms and light weapons
UNPoA	United Nations Program of Action to Prevent, Combat and Eradicate the Illicit Trade in Small Arms and Light Weapons in All Its Aspects